



NEBRASKA LAUNCH GUIDE

A GUIDE FOR NEBRASKA HIGH SCHOOL STUDENTS
USE FOR ALL POSTSECONDARY NEEDS

This guide belongs to:

My CliftonStrengths:

My postsecondary destination:

- University
- Community College-Transfer
- Community College
- Technical Institute
- Workforce / Apprenticeship
- Military

Important Contacts

School Counselor:

Phone or Email:

Other Educator:

Phone or Email:

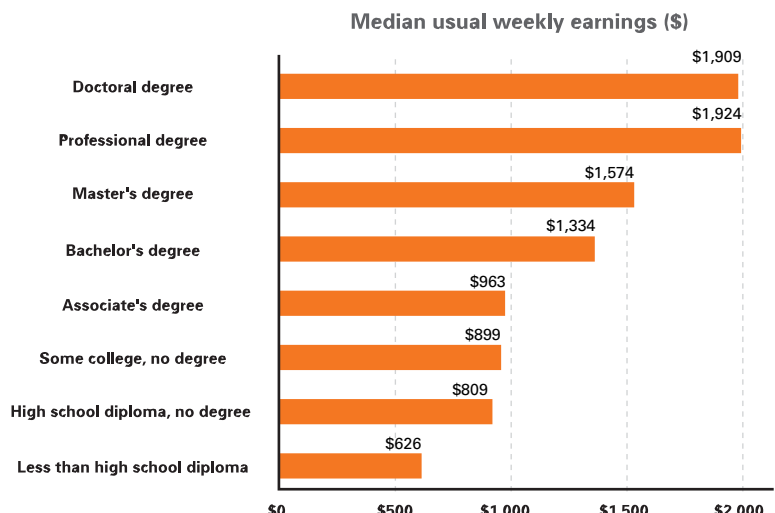
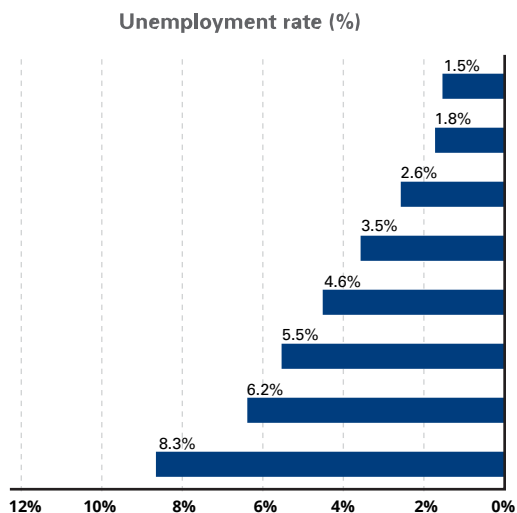

Note: Data for persons age 25 and over. Earnings for full full-time wage & salary workers. Source: U.S. Bureau of Labor Statistics, Current Population Survey

Senior Year!

You've been dreaming for years about what you'll do after you graduate, and this is the year you'll take many **critical** steps to launch your dreams into reality.

crit·i·cal /'kridak(ə)!/

adjective

Having a decisive or crucial importance in the success, failure, or existence of something.

"Submitting a college application before the deadline is a critical factor in getting accepted to college."

Synonyms: crucial, vital, essential, important, paramount, key, pivotal.

"The completion of FAFSA is critical for obtaining financial aid."

Section 1 of this Guide outlines the actions you need to take during your senior year, depending on what you want to do after high school, and Sections 2 through 8 provide important information and resources to help you take those actions.

If you are not sure what postsecondary track is right for you, answer the four questions on the next page to get a better idea of what postsecondary track might be best for you.

Beginning with Section 1, look for the checklist that applies to you—based on whether you plan to:

- Attend a four-year college or **university** to earn a bachelor's degree.
- Enroll in a **community college** first, then **transfer** to a university after 2 or 3 years to earn a bachelor's degree.
- Earn an associate degree or certificate at a **community college**.

- Earn a certificate or license in a skilled trade at a **technical institute**.
- Enlist in the **military**.
- Immediately enter the **workforce**.

The checklist for each plan provides timelines for completing each action, but you'll need to pay attention to specific deadlines and due dates since they vary.

Beyond Section 1, you'll find resources and information on everything from financing your college education to writing a resume. You'll also find helpful tools for tracking the status of your college, scholarship, and job applications, and we've provided space to record important information you'll need throughout the year.

Did you know UNL, UNO, UNK & UNMC now offer free undergraduate tuition to eligible students? You can check the scholarship section for more details.



We know you're excited to graduate, but don't catch senioritis. Stay focused on classes and postsecondary plans. This Guide will help launch you into your future, so keep it close all year long.

And don't forget, your school counselors and teachers are here to help you through every step.



Which Postsecondary Track may be right for you?

If you need help with choosing what type of postsecondary track is right for you, answer the four questions below. The letter you chose the most aligns with how you prefer to learn. Check the bottom of the page for the postsecondary school that could most closely align with your learning preferences. For a more in-depth exploration of postsecondary paths, see [Section 7](#).

How do you prefer to learn the basics?

- A. Listening to a teacher, reading about a subject, and possibly hands-on application subjects once I'm knowledgeable about the subject.
- B. Small classes that combine listening to a directly put to use teacher and book work.
- C. Small classes that combine listening to an hands-on skills instructor, watching an instructor perform an example, book work, and hands-on training. specialized skills in that particular field
- D. Instruction combined with watching an example and then hands-on work.

Which would you rather do?

- A. Get involved in a campus community (Greek, Sports, Clubs)
- B. Gain professional knowledge that can be used to provide paid professional consulting to my community
- C. Gain a set of skills in a particular field in a relatively short period of time, and use them later on to provide a paid service to my community
- D. Gain a set of specialized skills tailored to an employer's needs, and get paid in the process

How much variety would you like?

- A. Education that includes a variety of topics and subjects
- B. A framework of information that I could directly put to use
- C. Some variety in my education but focused on hands-on skills
- D. Focus on one field, and acquire a set of specialized skills in that particular field

How do you prefer to learn the basics?

- A. Researching, analyzing, and synthesizing information to become highly knowledgeable about the world and my field
- B. Combining research with pertinent information from a teacher to gain understanding about a topic that will directly benefit me or my community
- C. Learning a set of skills through hands-on that lead directly to a specific job/career
- D. Starting a job with progressive wage increases as my knowledge and skill levels increase

Which letter did you select the most?

U A. **Four-Year Colleges & Universities** offer a broad array of bachelor's degrees, also called the baccalaureate Bachelor of Arts or Bachelor of Science. Many also offer vocational certificates, associate and master's degrees.

Tr B. **Community Colleges** usually serve city, borough, or region residents. They typically offer vocational certificates and associate degrees and have minimal entrance requirements.

Cc

Ti C. **Vocational Schools & Colleges** offer career and technical training in a hands-on environment near your community.

W D. **Apprenticeships / Workforce** start you working from day one with on-the-job training and technical instruction. It can take one to six years for individuals to receive an industry-recognized credential that certifies occupational proficiency.

Launch Guide Table of Contents

7

SECTION 1

Checklists: Actions and Timetables

- 8 Senior Checklist for College
- 9 Stay on Track
- 10 Four-Year University
- 11 Community College
- 12 Technical Institute / School
- 13 Workforce / Apprenticeship
- 14 Military Enlistment

15

SECTION 2

Flight Preparations: College Application Process

- 16 Collect Your Personal Information
- 19 What is the Best Fit for Me?
- 21 Colleges in Nebraska
- 22 Keep Track of College Applications
- 24 Should I Take or Retake College Entrance Exams?
- 25 ACT vs. SAT
- 26 What are College Placement Tests?
- 27 You're Accepted...Now What?
- 28 Post-Acceptance Checklist
- 30 Community College Transfer Options

31

SECTION 3

Secure Funding: Financial Aid

- 32 What is Financial Aid?
- 33 FAFSA (Free Application for Federal Student Aid) Facts
- 34 Pre-FAFSA Information
- 35 FSA (Federal Student Aid) ID Form
- 36 What Is My Dependency Status?
- 38 FAFSA Submission Summary
- 49 Financial Aid Offers
- 39 What Is FAFSA Verification?
- 40 What to Expect After Submitting Your FAFSA

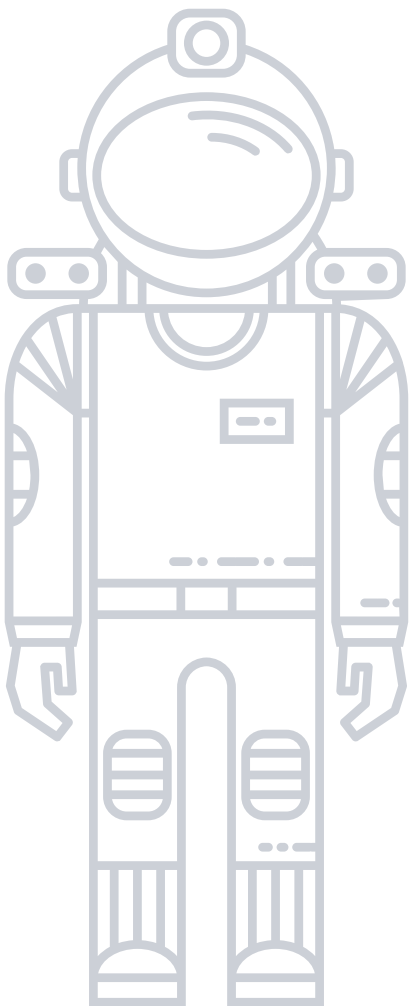

41 **SECTION 4** **Help with Lift-Off: Scholarships and Jobs**

- 42 Scholarships: Free Money Awaits
- 43 Craft a Personal Statement
- 44 Write a Stand-Out Essay
- 45 References and Recommendations
- 46 Employment
- 47 Resume and Job Application Information
- 49 Create a Resume
- 50 Sample Resume
- 51 Tracking Community Service
- 52 Tracking Scholarship Applications
- 53 Tracking Job Applications
- 54 Notes for Scholarships and Jobs

55 **SECTION 5** **One Small Step, One Giant Leap: A Future in the Military**

- 56 Enlisting vs. ROTC

57 **SECTION 6** **Reach for the Stars: Resources for Undocumented Students**

- 58 A Pathway to College for ALL Students
- 59 Four Things You Need to Know about College
- 60 Questions and Answers about Paying for College

61 **SECTION 7** **How to Decide**

- 62 I'm uncertain about plans after high school.
- 63 Stage 1 – Dream
- 64 Stage 2 – Explore
- 65 Stage 3 – Plan
- 66 Stage 4 – Assess
- 67 University Readiness Assessment
- 69 Community College Readiness Assessment
- 71 Technical School Readiness Assessment
- 73 Apprenticeship / Work Readiness Assessment
- 75 Military Readiness Assessment

77 **SECTION 8** **Glossary**

- 78 Glossary
- 82 Usernames and Passwords

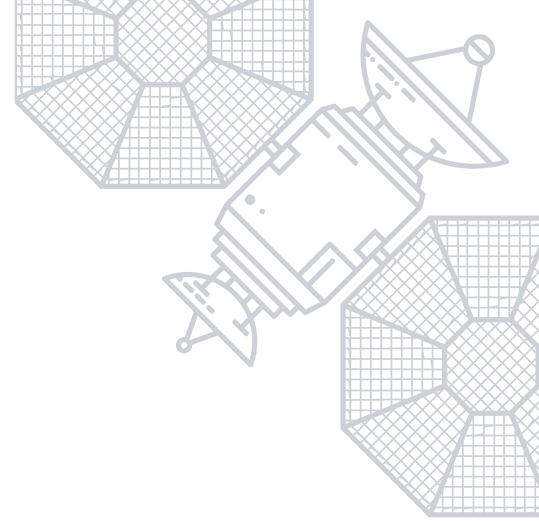

The background is a solid blue color with various white line-art elements. On the left, there is a large globe with horizontal lines representing latitude. At the bottom, there is a satellite with solar panels. Several curved lines represent orbital paths or trajectories. There are also various circles and dots scattered throughout, some resembling stars or planets. The text is centered on the right side of the page.

Section 1: Checklists: Actions and Timelines

Senior Checklist for College:

To stay on track for graduation follow each objective for the month. Behind on a task or needing help? Contact your Gear Up senior advisor.

August

- Research colleges & majors, create a list of schools to apply to
- Meet with a counselor to ensure on track to meet graduation and college admission requirements
- Finish ACE scholarship for dual-credit classes
- Create strong relationships with teachers/other GISH staff and community members for future letters of recommendation
- Begin to take an active role in the community through volunteering experiences

September

- Take any final college visits to solidify where you want to apply
- September ACT (register early August)
- Attend the College Fair to talk directly with a college representative about programs/majors/scholarships
- Search for Scholarships and create a master list of scholarships applicable to your schools/programs of choice (include deadline and requirements for each)
- Apply to all University of Nebraska schools at no charge for early admission = scholarships

October

- Attend Gear Up's Personal Essay Workshops with Joaquin for a headstart on college essays
- October ACT (register by mid-September) *last chance to get scores before most scholarships are due*
- Attend College Fair (get all your questions answered!)
- Create your own FAFSA FSA ID and have your parents create one with verification KEEP USERNAME / PASSWORD SAFE AND IN AN ACCESSIBLE PLACE
- Finish applying to colleges for early decision (last chance to apply for early decision and be considered for the first round of scholarships due by November 1)

November

- Continue applying to colleges for regular decision
- Begin applying to scholarships, set aside time each week until March to complete scholarships
- Update Resume, meet with Mrs. Soundy or GUGI Staff for additional help

December

- December ACT (register by early November)
- Fill out FAFSA (have FSA ID for you and your parent(s))
- Set an appointment with EducationQuest or GUGI for help completing the FAFSA
- Midterm Graduation if applicable

- GIPS Foundation Scholarship opens December 10 (complete early for extra points, which can help win \$\$)
- Watch for acceptance letters from colleges and scholarships, keep them handy, and regularly check email for updates
- Expect financial aid offers from the colleges listed, keep in mind additional scholarships, and feel empowered to choose the 'best deal' for you

January

- Understand the FAFSA report and Submission Summary (what it means for your financial contribution)
- Ensure class requirements, grades, and attendance are being fulfilled for May graduation

February

- Buffet scholarship deadline February 1st (APPLY even if UN schools are not your first option)
- Grand Island Community Foundation Scholarship deadline
- GIPS Foundation scholarships deadline February 10

March

- Attend the Hiring Fair (March 30-31)
- Compare financial aid offers
- Continue to apply for scholarships
 - Check within colleges you have been accepted to for their list of scholarships

April

- Honors night April 10, 6:30-8:00 pm
- Send FAFSA/SRA to Colleges (if not originally listed in your form)
- Look at detailed financial aid packages and choose a college, determine your contribution
- Update West office on scholarship reporting for graduation program by April 26

May

- Commit to a university by May 1, pay the fee
- Submit your campus housing registration fee and deposit
- Register for new-student orientation at your college
- Graduation eligibility deadline May 2
- Cap & Gown payment due early May
- Fines due early May (must be at \$0 to graduate)
- Last day of school, May 9 (Class day & graduation rehearsal, must be present to walk on Sunday)
- *Must complete Exit form to graduate*
- Graduation: May 12

Stay on Track

Do you already know your destination for the fall (after high school graduation)? If you plan on one of the options below, begin in the corresponding section of the Guide.

- University
- Community College / Transfer
- Technical Institute
- Workforce / Apprenticeship
- Military

If you're unsure, refer to the four questions on page 3 or use the tools and resources in Section 7 to help you decide.

Whatever your plans after high school, this Guide will keep you organized and on track to reach your goals. We've created a key on the right, and on each page of the Guide, you'll find the corresponding symbols for resources needed for your individualized plan.

First, review the postsecondary options—it will show the complete picture of all your choices and steps needed to get there. Then, choose the postsecondary option that fits you and dig in. From there, explore the rest of the Guide as you keep a lookout for the symbols that match your path. Along the way, you'll also find information about how to pay for college, scholarships, financial aid, resumes, and much more. If you're unsure or have questions, check in with your school counselor.



Make sure to stay on track with college deadlines and work ahead of time! Most scholarship deadlines are due February 1 or earlier.

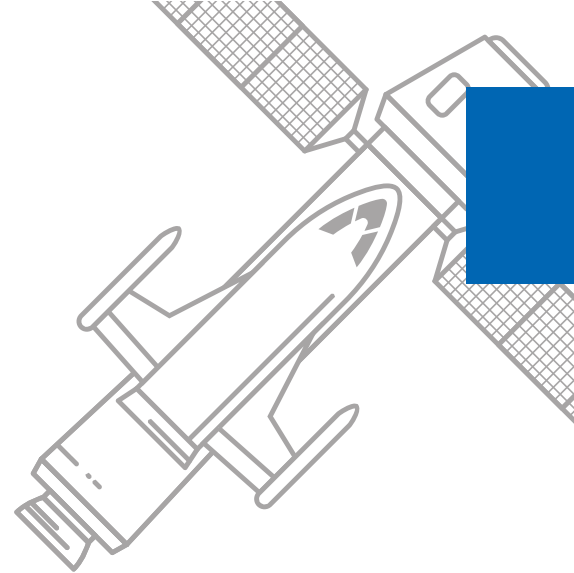

If you plan to...	Look for Symbol
Attend university next year	U
Enroll in a community college first and then transfer to a university	Tr
Enroll in a community college to earn an associate degree or certificate	Cc
Attend a technical institute next year	Ti
Enter the workforce or an apprenticeship after graduation	W
Enlist in the military	M

Four-Year University

If you plan to attend a four-year college or university and earn a bachelor’s degree (including ROTC programs and military academies), this checklist is for you.

My top three schools of choice, (see Section 2, page 19 for resources to help select schools):

1. _____
2. _____
3. _____

I’m interested in the following majors:

1. _____
2. _____
3. _____

	Action Steps	Recommended Timeline	My Date	Notes
College Application Process	Obtain college application fee waiver(s)	Aug - Sept		
	Complete college app(s), including fee or using fee waiver (usually online)	Aug - Sept		
	Request / mail transcripts from GISH & Wayne (& AP test scores if applicable)	Within one week of completing college app		
	Register to take or retake ACT / SAT (if school requires the ACT / SAT)	Prepare: July - Oct Retake: Nov - Dec		
	Report ACT / SAT scores to schools	Aug - Dec		
	Explore ROTC or officer programs	Aug - Dec		
	Obtain FSA ID (student & parent)	Aug - Dec		
	Complete FAFSA	Dec (2023) Oct (2024+)		
	Review FAFSA Submission Summary	Oct - Dec		
	Complete scholarship apps (personal essay)	Aug - May		
	Review admission letters and financial awards	Oct - Apr		
	Check your college account to see if FAFSA verification needs to be completed	Oct - June		
College Acceptance	Accept admission at school of choice	As early as you know - by May		
	Pay or defer enrollment deposit to selected school	After accepting admission - Spring		
	Register for orientation	After accepting admission - Spring		
	Apply for housing	After accepting admission - Spring		
	Learn about TRiO / bridge programs & apply	After accepting admission - Spring		
	Inform Counselor of decisions & awards	Spring		
	Other:			



Community College (transfer, associate degree, or certificate)

Community colleges offer associate degrees or professional certificate programs. Also, if you want to earn a bachelor’s degree, you can start at a community college, and then transfer to a four-year university.

My top schools of choice are (see Section 2, page 19 for resources to help select schools):

1. _____
2. _____
3. _____

The degree I will pursue (circle one):

- Transfer (2 or 3 years at the community college, plus 1 or 2 at a university)
- Associate degree (2 years)
- Certificate (culinary arts or fire science, for example)

If you know what career you want to pursue, but you're not sure how much education you need, visit <https://www.bls.gov/emp/tables/education-and-training-by-occupation.htm> to learn about educational requirements, pay, and the outlook for the profession

	Action Steps	Recommended Timeline	My Date	Notes
College Application Process	Obtain college application fee waiver (s)	Aug - Sept		
	Complete college app(s), including fee or using fee waiver (usually online)	Aug - Sept		
	Request / mail transcripts (& AP test scores if applicable)	Within one week of completing college app		
	Prep for and take / retake placement tests (e.g., Accuplacer)	July - Oct (prep) Nov - Dec (take / retake)		
	Obtain FSA ID (student & parent)	July - Sept		
	Complete FAFSA	Dec (2023) Oct (2024+)		
	Review FAFSA Submission Summary	Oct - Dec		
	Complete scholarship apps (personal essay)	Aug - May		
	Review admission letters and financial awards	Oct - Apr		
	Check your college account to see if FAFSA verification	Oct - June		
College Acceptance	Accept admission at school of choice	As early as you know - by May		
	Talk with a community college academic advisor	Mar - May		
	Apply for housing	After accepting admission - Spring		
	Explore program of study (including transfer programs)	Spring		
	Learn about TRIO / bridge programs & apply	After accepting admission - Spring		
	Inform Counselor of decisions & awards	Spring		
	Other:			

Technical Institute / School

If you want to attend a technical institute / school and obtain a certificate or license in a skilled trade, this checklist is for you! At tech schools, you can train to become a certified professional in a variety of fields, such as a motorcycle mechanic, a nurse (CNA or LPN), or a computer technician.

My top schools of choice are:

I'm interested in pursuing a career in:

1. _____
2. _____
3. _____

If you know what career you want to pursue, but you're not sure how much education you need, visit <https://www.bls.gov/emp/tables/education-and-training-by-occupation.htm> to learn more about educational requirements, pay, and the outlook for the profession.

Action Steps	Recommended Timeline	My Date	Notes
Find out if a similar program is offered at a community college and compare costs	Aug - Dec		
Obtain app fee waiver(s)	Aug - Dec		
Complete tech school application(s) (usually online)	Feb		
Send add'l requirements (transcript, test scores, portfolio, etc.)	Aug - Dec		
Obtain FSA ID (student & parent)	Jul - Sept		
Complete FAFSA	Dec (2023) Oct (2024+)		
Review FAFSA submission summary	Oct - Dec		
Complete scholarship apps (personal essay)	Aug - May		
Review admission letters and financial awards	Oct - Apr		
Check your student account to see if FAFSA verification needs to be completed	Oct - June		
Accept admission at school of choice	As early as you know - by May		
Explore career outlook	Mar - May		
Apply for housing	After accepting admission - Spring		
Inform Counselor of decisions & awards	After accepting admission - Spring		
Other:			

Workforce / Apprenticeship

If you plan to enter the workforce immediately after high school graduation, then this checklist is for you!

My job prospects include (See Section 4, pages 45 – 50 for resources that may help you apply for jobs):

1. _____
2. _____
3. _____

Visit <https://www.bls.gov/emp/tables/education-and-training-by-occupation.htm> to learn more about educational requirements, pay, and the outlook for the fields you're considering pursuing after graduation.

Action Steps	Recommended Timeline	My Date	Notes
Research training required for field of interest	Fall / Winter		
Research community college options / programs	Fall / Winter		
Ask people to serve as references	Spring		
Create / update resume (See Section 4, pg. 49-50)	Winter / Spring		
Research job openings	Spring		
Gather documents needed for completing job applications (See pages 49–51) for details	Winter / Spring		
Apply for jobs	Spring		
Request letters of recommendation	As required for application		
Inform Counselor of job placement	As soon as you're hired – May at latest		
Other:			
Other:			

Military Enlistment

If you plan to enlist in the military immediately after high school, then this checklist is for you!

Section 5 has more details on entering military service.

I plan to join the:

Army

Navy

Air Force

Marines

Coast Guard

If you are interested in ROTC, use the university checklist on page 10.

Action Steps	Recommended Timeline	My Date	Notes
Schedule appointment with Military Recruiter	Fall		
Take or retake ASVAB	Fall		
Discuss Delayed Entry Program with recruiter	Fall		
Complete physical examination with Military Entrance Processing Station (MEPS)	As directed by recruiter (Fall / Winter)		
Review ASVAB scores with School Counselor	Spring		
Research potential careers for service	Spring		
Meet with Enlistment Counselor to determine career prospects	As directed by recruiter		
Take the Oath of Enlistment	As directed by recruiter		
Prepare for Boot Camp	Spring		
Other:			

Section 2: College Application Process

Take Your Education to the Next Level

If you plan to go to a four-year university, community college, or technical school, this section will help you soar. You'll find out how to choose a school, submit applications, prepare for and take college-entrance exams. And, if you decide to start at a community college, you'll also find resources to make a smooth transition to a university.

For details on paying for college, see sections 3 and 4.



SECTION 2

Collect Your Personal Information

Take a few minutes to fill out this form. Then with your high school **transcript** in hand, you'll have everything you need to complete most college applications. You might need to work with your parent or family members to get all the details.

When it comes time to apply, many universities charge a fee up to \$100. However, universities often waive fees, so ask your School Counselor how to proceed.

Leave areas blank if they don't apply to you.

Contact Information	
Full Name (first, middle, last)	
Street Address	
PO Box	
City, State, Zip Code	
Home Phone Number	
Mobile Phone Number	
Email Address (not your high school email address, create a new one if needed)	
Social Security Number	
Driver's License Number and Date Issued	
Date of Birth	
School Information	
Name of Current High School	
Street Address, City, State, Zip Code	
Telephone Number	
Expected Graduation Date	
Name of Previous High School Attended	
Street Address, City, State, Zip Code	
Telephone Number	
Dates Attended	
Colleges Attended / College Credits Earned	
(List any college from which you expect to receive credit—including dual enrollment or concurrent enrollment).	
College Name	
Street Address, City, State, Zip Code	
Dates Attended	
Course Name / Number of Credits	
Course Name / Number of Credits	

Collect Your Personal Information



GPA and Testing (ACT, SAT, AP, WSC, & placement test),					
Weighted GPA		Unweighted GPA			
SAT Date (month / year)		Comp Score			
ACT Date (month / year)		Comp Score			
AP Subject	Score	AP Subject	Score		
AP Subject	Score	AP Subject	Score		
WSC Subject	Score	WSC Subject	Score		
College Placement Exam Name	Date(s)	Subject / Score			

Athletics, Clubs, and Organizations				
List Name of Club / Sports Team	List your role / position each year			
	Freshman	Sophomore	Junior	Senior

Collect Your Personal Information

Honors & Awards		
Name and Date of Award	Reason for Award / Honor	Sponsor

Community Service					
Name of the organization	Description of volunteer service	Dates of service	Number of hours of service	Take-aways: What you learned, enjoyed, experienced	Name of contact and contact information (email, phone, website, and / or address)

Family Information and Other Personal Information

Student's status:

- US Citizen
 Permanent US Resident
 Refugee
 Asylee
 DACA
 Undocumented

State of residence: _____

Has either of your parents earned a bachelor's degree or higher? Yes No

Are your parents affiliated with the US military? Yes No

Emergency Contact

Name / Relationship: _____

Phone Number: _____

Address: _____



What is the Best Fit for Me?

Deciding which college to attend can be a challenge—there are so many factors to consider. What’s important to you in a college experience? Take a look at your long-term goals and how college will help you get there. Visit college websites, take virtual tours, talk to current and former students, and read online reviews. In other words, learn as much as you can about potential college choices.

Below are some things you might want to consider as you research.

How would you rank / order what is most important to you?

<p>Type of School</p> <ul style="list-style-type: none"> • Two-year or four-year • Public or private • University / research institution or liberal arts college • All-male, all-female, or coed • Religious or secular 	<p>Student Life</p> <ul style="list-style-type: none"> • On and off campus activities • Athletics • Greek life • Student organizations • Safety • Student body diversity 	<p>Location</p> <ul style="list-style-type: none"> • Urban or rural • Size of nearest city • Distance from home • Geographic setting and weather
<p>Affordability</p> <ul style="list-style-type: none"> • Cost of attendance (tuition, fees, transportation, housing) • Scholarships • Campus employment opportunities 	<p>Admission Requirements</p> <ul style="list-style-type: none"> • Minimum GPA • Average test scores • Required high school courses • Likelihood of being accepted 	<p>Housing</p> <ul style="list-style-type: none"> • Residence halls • On and off campus housing • Meal plan • Parking for residents and for commuters
<p>Academics</p> <ul style="list-style-type: none"> • Programs and majors offered • Student - faculty ratio • Accreditation 	<p>Size</p> <ul style="list-style-type: none"> • Physical enrollment • Average class size • Physical size of campus 	<p>Other criteria important to you</p> <ul style="list-style-type: none"> • • •

U

Tr

Cc

Ti

How do the schools you're interested in measure up? Here's a chart to help you compare the colleges you are interested in, and the criteria that are most important to you.

	College:	College:	College:	College:
Criteria				
Type of School				
Student Life				
Location				
Affordability				
Admission Requirements				
Housing				
Academics				
Size				
Other				
Other				
Other				

Colleges in Nebraska

- | | | |
|--|--|--|
| 1 Bellevue University
<i>www.bellevue.edu</i> | 7 Doane University
<i>www.doane.edu</i> | 13 University of Nebraska - Lincoln
<i>www.unl.edu</i> |
| 2 Bryan College of Health Sciences
<i>www.bryanhealthcollege.edu</i> | 8 Midland University
<i>www.midlandu.edu</i> | 14 University of Nebraska Medical Center
<i>www.unmc.edu</i> |
| 3 Central Community College
<i>www.cccneb.edu</i> | 9 Nebraska Methodist College
<i>www.methodistcollege.edu</i> | 15 University of Nebraska - Omaha
<i>www.unomaha.edu</i> |
| 4 Chadron State College
<i>www.csc.edu</i> | 10 <i>Peru State College</i>
<i>www.peru.edu</i> | 16 Wayne State College
<i>www.wsc.edu</i> |
| 5 Concordia University
<i>www.cune.edu</i> | 11 <i>College of Saint Mary</i>
<i>www.csm.edu</i> | 17 Nebraska Wesleyan University
<i>www.nebrwesleyan.edu</i> |
| 6 Creighton University
<i>www.creighton.edu</i> | 12 <i>University of Nebraska Kearney</i>
<i>www.unk.edu</i> | |



Smart \$ Tip:
If you are a resident of Nebraska, in-state tuition will be *much* cheaper than an out-of-state university.

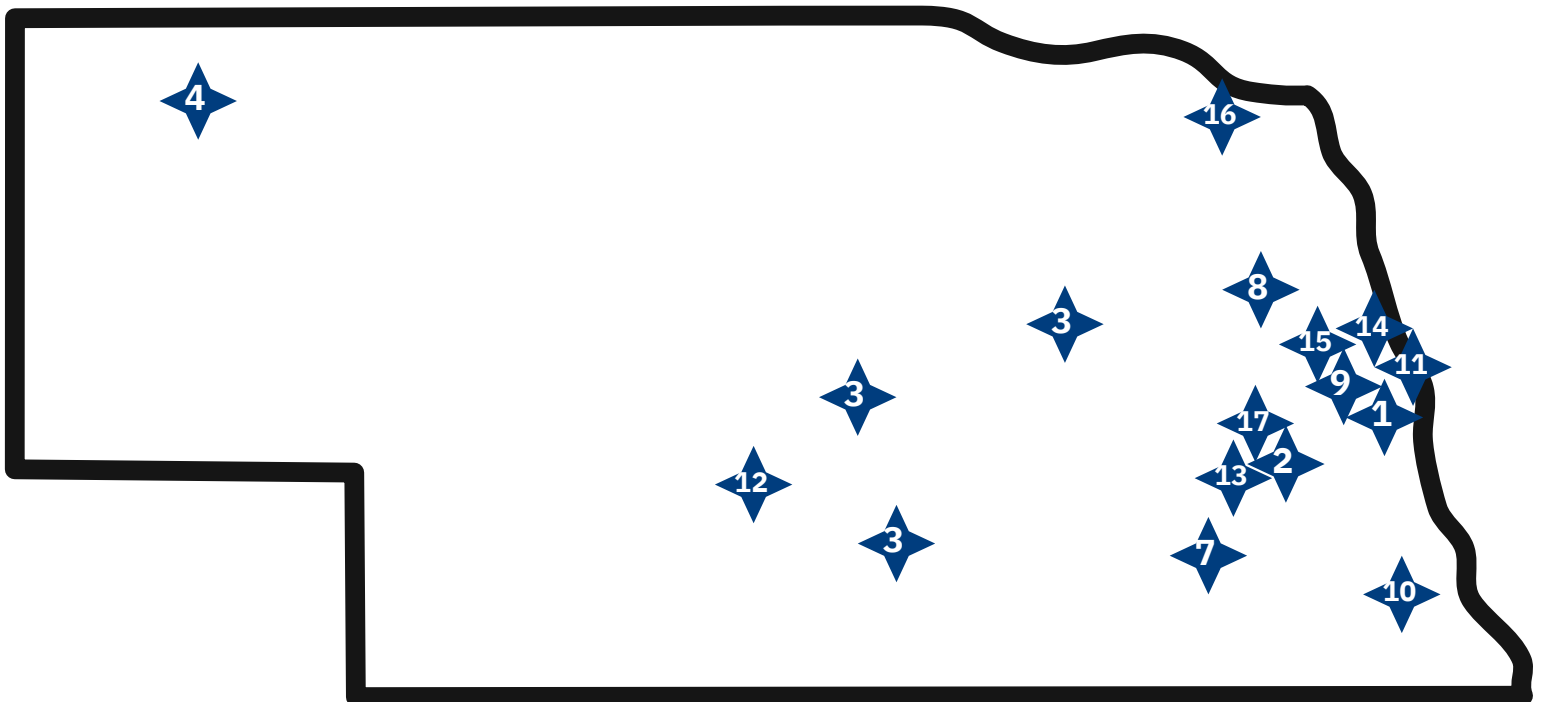

Keep Track of College Applications

As you begin the college application process, apply to a variety of colleges, including a safe choice, a realistic choice, and a reach. Get the scoop on each type on the next couple of pages.

- **Safe choice:** Your academic credentials fall above the school's range for the average freshman. It's safe to anticipate acceptance.
- **Realistic choice:** Your academic credentials fall within (or even exceed) the school's range for the average freshman. There are no guarantees, but it's reasonable to expect acceptance.
- **Reach choice:** Your academic credentials fall below admission guidelines, but it's important to reach for the stars. Go for it, and apply to that selective dream school.

Use this table to keep track of your progress on your college applications:

Tracking College Applications				
	Application deadline (note priority deadline, if applicable)	Date you applied	Date you sent application payment / waiver	Date your HS sent your official transcript
College #1				
College #2				
College #3				
College #4				
College #5				

Keep Track of College Applications

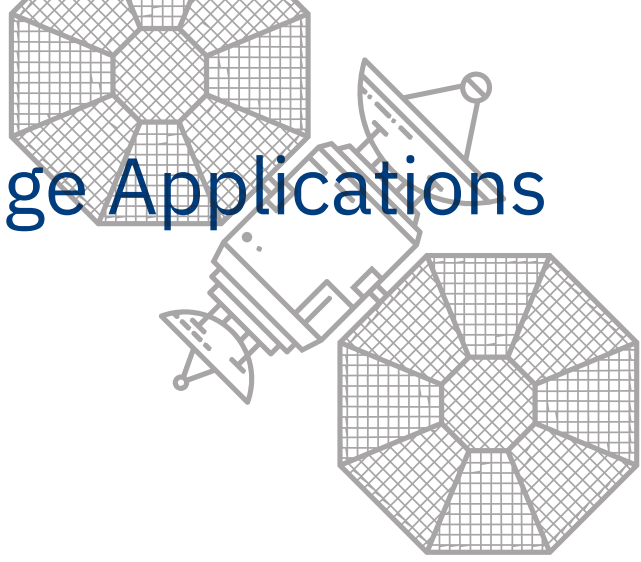

Date you sent college transcript, if applicable	Date you sent test scores: AP, ACT, SAT (if applicable)	College acceptance Yes or No	Financial award letter received and reviewed Yes or No

Should I Take or Retake College Entrance Exams?

The ACT and SAT are college admissions tests. Many colleges and programs use ACT or SAT scores in their admission decisions, although some do not, and some specifically require one test or the other. Generally, Nebraska's three state universities don't require certain scores; however, some majors use the scores in admission decisions. Also, universities often use ACT / SAT scores to place students in specific courses, particularly for math. Additionally, universities use these tests to determine merit-based scholarships. The higher the score, the more free money you earn!

I already took the ACT or SAT as a junior. Should I retake it senior year? Once you've received your test scores(s) report, take a moment to congratulate yourself! Completing a three-hour exam is an accomplishment in itself. Next, realize that sometimes students need to take the ACT or SAT two or three times to maximize their score. This is completely normal; in fact, most students take these exams more than once. Some students take both tests to see which one they do better on, then retake only the one exam they did better on to see if they could improve that score. Here's how to decide whether you should retake one or another:

- 1. What scores do I need for my target universities and scholarships?** Take a moment to research the schools you want to attend. Many schools list the average or mid-range SAT and ACT scores for their admitted students on their website (check the Admissions section). Aim to be at or above their posted average score, but keep in mind that extracurriculars and GPA also factor into the admission decision. Use the "scholarship estimator" tools on college websites to figure out whether a higher score could earn you a bigger scholarship. If so, how likely is it you could improve your score?
- 2. How many times have you already taken each test?** Although retaking the test can raise your score, after the third attempt, it's unlikely to raise your score unless your preparation is drastically different. Go ahead and retake, but change the way you prepare between exams.
- 3. Are my score expectations realistic?** With effort, increasing your ACT score by 3 or 4 points on your second attempt is realistic. For the SAT, well-prepared students can see a 40-point increase on the retake. So, look at where you are and what the college expects to determine if a retake makes sense. Also, the higher your score, the harder it is to raise it with future retakes. For example, if you retake the ACT and score a 34, it's unlikely it will improve on the third attempt. Again, preparation between retakes is key.
- 4. How do I move forward?** If you've considered these questions and come to the conclusion that you don't want or need to retake either test, congratulations! Focus on completing your applications and essays, and on making a strong finish in your high school career. If you decide to retake the ACT or SAT, then pick a test date that fits your schedule and deadlines and start using the prep tools available.

For the SAT, free online prep is available at www.khanacademy.org/SAT; ACT prep is available at www.act.org/the-act/testprep. Look closely at these tools. Some are free and others are not. Ask your School Counselor for test prep resources at your school.

Sources: testive.com and act.org/content/dam/act/unsecured/documents/ACT-Score-Report-eBook.pdf

ACT vs. SAT

ACT	SAT
Total Time	
2 hours, 55 minutes (without writing) 3 hours, 35 minutes (with writing)	3 hours (without essay) 3 hours, 50 minutes (with essay)
Subjects and Time (in order they appear on test)	
1. English: 45 mins, 75 questions 2. Math: 60 mins, 60 questions 3. Reading: 35 mins, 40 questions 4. Science: 35 mins, 40 questions 5. Writing (optional): 40 mins, 1 essay	1. Reading: 65 mins, 52 questions 2. Writing and Language: 35 mins, 44 questions 3. Math: 80 mins, 58 questions 4. Essay (optional): 50 mins, 1 essay
Tools	
You can use a calculator on all math questions.	Some math questions don't allow you to use a calculator.
Essay	
Optional. Essay assesses your writing skills and your ability to compare and contrast different perspectives. For the essay, you will read a short passage about an issue and then analyze the different perspectives on this issue. You'll be asked to give your own opinion on the issue.	Optional. Essay assesses your writing skills and your reading comprehension skills. For the essay, you will read a short passage about an issue. Your essay will analyze the author's argument using evidence and reasoning. In other words, you will not be giving your own opinion.
Score	
Total score range: 1 – 36 Each section uses a scale of 1 – 36. Your total score is the average of your four section scores. The optional Writing section uses a scale of 2 – 12 and does not count toward your final score.	Total score range: 400 – 1600 The Evidence-Based Reading and Writing (EBRW) and Math sections each use a scale of 200 – 800 and are combined for a total score. The optional Essay uses three separate scales of 2 – 8 and does not count toward your final score.
Accommodations	
English Learners and students with documented disabilities can request accommodations.	Students with disabilities can request accommodations.
Registration and Preparation Tools available at:	
www.act.org/	satsuite.collegeboard.org/sat

Need to retake the SAT or ACT? Talk to your School Counselor to find out about test dates, test fee waivers, and test prep options. You must register five weeks before the test date!



Adapted from:

<http://www.act.org/>

<https://collegereadiness.collegeboard.org/sat>

<https://blog.prepscholar.com/act-vs-sat>

SECTION 2

What are College Placement Tests?

After you accept admission, you may need to take placement tests in subjects like math and English to ensure you're placed in the appropriate-level courses.

Who Uses Placement Tests? Almost all two-year colleges and many public four-year colleges require new students to take at least one placement test before registering for classes. Some private four-year colleges also use these tests.

What Are Placement Tests Like? Colleges use several common placement tests. The tests usually measure skills in these subjects:

- Math
- Reading
- Writing

Some placement tests are given online, and you receive scores as soon as you finish. Several states and individual colleges have developed their own placement tests.

How Can I Prepare? Placement tests measure the skills you've already learned in high school, so your preparation should include reviewing sample questions to learn what topics to brush up on. To get ready for these tests, you can:

- First, check with an admission officer at your college to find out if you must take a placement test.
- If so, find out what subjects the test will cover.
- Check the college website for information about the test and ways to prepare.

What Do the Results Mean? Your test results may mean that you can skip some introductory courses, or they can show that you need more preparation before taking on college-level work.

If you need more preparation, a college may require you to take a remedial course.

What Are Remedial Courses? Remedial classes help improve your skills in a subject to prepare you for the rigor of college in classes like math and English. Don't get discouraged. These classes will show your strengths and weaknesses, so you'll know where to focus. They also increase your likelihood of academic success.

What Happens After I Take the Test? Once your test results are available, you may be assigned automatically to the course level that fits you best, or you may meet with your academic advisor to choose your courses.

Adapted from: collegeboard.org

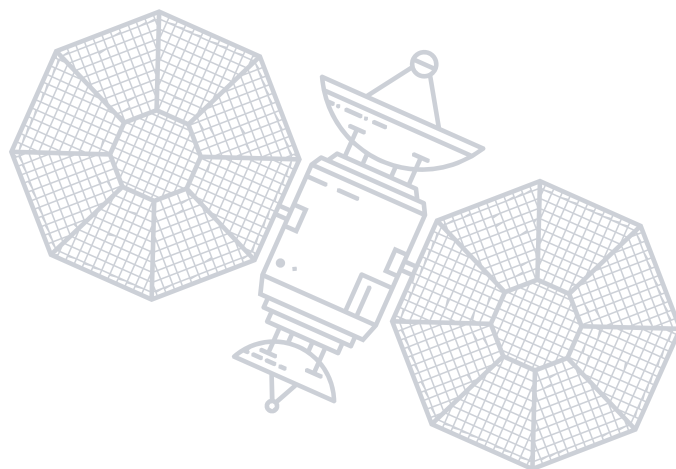

You're Accepted...Now What?

Once you've received your acceptance letters and decided on a school, there are still a few actions you'll take to secure your spot. Plus, you'll want to keep track of some key information.

Use the checklist on the following pages to help you keep everything organized and on time.



Be sure to check your college email account regularly.

If you have questions about processes or next steps, check in with your college representative, financial aid counselor, or admissions counselor.

The college I am attending: _____

My admissions counselor's name: _____

email: _____ phone: _____

My financial aid counselor's name: _____

email: _____ phone: _____

My college username: _____ email: _____

My college ID #: _____



Your college username / ID will help you to log into your accounts to access housing, grades, meal plans, etc. Set this up early!

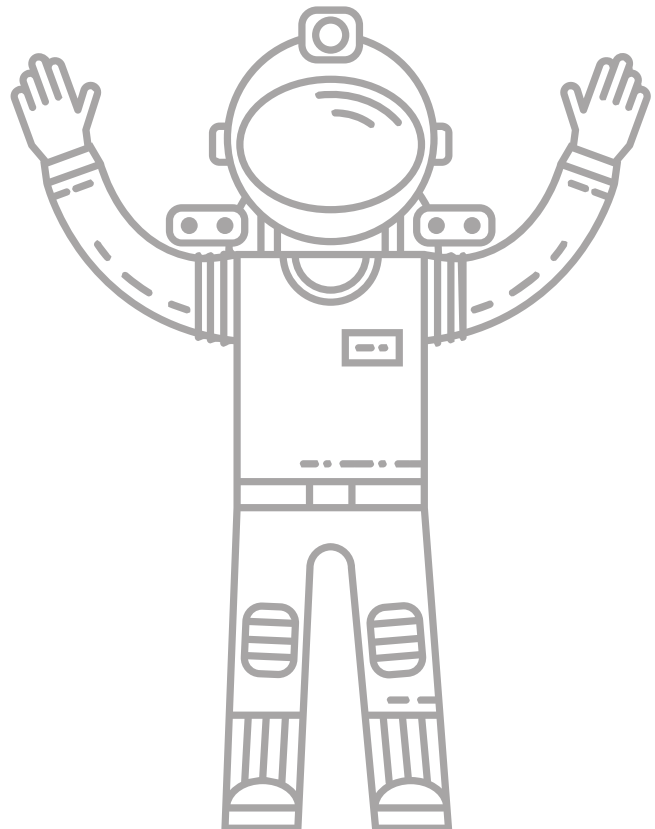

Post-Acceptance Checklist

After you accept admission into the college of your choice, there will be important tasks you'll need to complete in the months before the first day of college. Your college will communicate through your new student account and email, so check it regularly so you don't miss any deadlines. This checklist includes steps that are common for new college students.

Pay or Defer your enrollment deposit.

The enrollment deposit confirms your acceptance and begins the process of signing up for an orientation. If you're eligible for a Pell Grant—and other circumstances—you can request a deferment, which means you would pay the deposit later. Contact your college to ask about deferment.

Review financial aid offers and accept / decline awards. Check if you were selected for FAFSA verification.

Check for important financial aid status on your student account and email. You may need to submit additional paperwork for scholarships or your Pell Grant. This step is crucial to ensure you receive funding for school, and deadlines are strict. (See page 39 for more info on FAFSA verification.)

Send enrollment information to scholarships like the GIPS foundation.

Many scholarships ask for proof of enrollment before sending funds to your University. This crucial step can be left forgotten, leading to lost scholarship dollars.

Apply for housing.

If you will live on-campus, review your housing options and apply / select the residence hall where you would like to live. This may require you to pay a housing deposit.

Take placement tests.

Many colleges will require you to take placement tests before registering for courses. You may need to schedule an in-person appointment at your college to take the tests, or you may receive an email with instructions on how to take the tests online. Either way, brush up on your math and English basics to prepare.

Participate in an orientation.

Review the orientation dates and options and select the earliest possible date that works with your schedule.

Send your final high school transcript (after high school graduation).

Most colleges will require you to submit your final high school transcript after graduation. Since many high school campuses are closed or have irregular hours during the summer, it's important to contact your school office, registrar, or counseling office BEFORE the last day of school to request they send your final transcript to your college. Write down the name and contact information of the person from your school who can answer transcript questions over the summer just in case you need it.

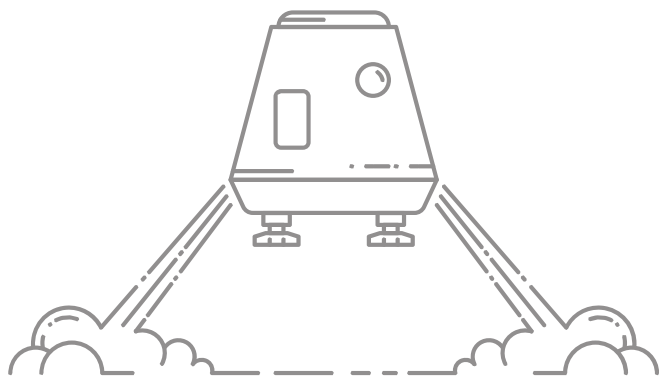

Name: _____
 Email: _____
 Phone: _____
 Office hours: _____

Register for courses.

Class registration varies from college to college. At some colleges, students meet with advisors during orientation to register for classes. Other colleges may require online registration. Either way, check your student email and account to get the details, and don't hesitate to make an appointment with an advisor if you have questions.

Submit your immunization records.

If you're required to submit immunization records, you can either scan and upload them on your university website or ask your high school to include immunization records on your official high school transcript.

Check the mail and email for invitations to the summer bridge programs at your college.

Summer bridge programs can give you a jump-start on adjusting to college. They can help get you up to speed on academic subjects before college, and you get the opportunity to meet other students. Ask about these programs and sign up!

You may complete more steps than the ones listed. Just remember - **ask questions if you have any doubts and check your email regularly**, so you don't miss any important reminders or deadlines.



My Status: Important Notes

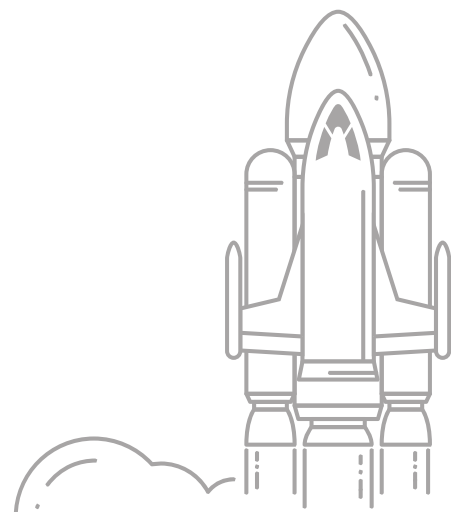

Community College Transfer Options

If you plan to attend a community college first and then transfer to a four-year university, it's important to learn about resources like Transfer Nebraska to help you keep on the right track and make sure your community college courses transfer to your university of choice and count toward your degree.

Meet with your community college advisor early and often—academic advisors are your key to a smooth transfer. Share your goals with your advisor so that they can help you understand the General Education Curriculum Requirements. Successfully completing these requirements means your courses will transfer from the community college to the Nebraska university of your choice.

Transferring is an option students may choose if they want flexible options before attaining a bachelor's degree. Your advisor will help you learn about specific transfer programs as well as help you monitor your progress and stay on track to complete your plan.

Building Your Transfer Degree

BACHELOR'S DEGREE
120 CREDITS

56 UNIVERSITY CREDITS

ASSOCIATE'S DEGREE
64 CREDITS

27-29 ELECTIVE & COMMON COURSE CREDITS

35-37 GENERAL EDUCATION CREDITS

CREDITS EARNED IN HIGH SCHOOL

DUAL ENROLLMENT CREDIT EXAM CREDITS (AP, IB, CAMBRIDGE)

transfer.nebraska.edu



Transfer Nebraska is a resource that shows you how to earn credit at your community college that will apply towards your bachelor's degree at any Nebraska College / University / institution. Search the Course Equivalency Guide to learn how courses transfer. Use the Exam Equivalency Guide to see how AP and IB exam scores translate to college credit.

Section 3: Secure Funding: Financial Aid

Identify Funding for College

If you're concerned about how you're going to pay for your college or career training consider this:

- College or career training might not cost as much as you think. In fact, most families overestimate the price tag.
- Fill out the FAFSA, and you may be eligible for free tuition at UNK, UNL, or UNO with the Nebraska Promise Program
- Help is available. Financial aid can make paying for school realistic and affordable.
- Your education is a long-term investment. On average, individuals with a college degree or career training credential earn twice as much as those with high school diplomas.

In this section, you will find information about types of financial aid, how to apply for aid, and how to interpret the financial aid offers you receive.

Section 4 of the Guide includes information on helping you pay for college or career training through scholarship and jobs.

What is Financial Aid?

Financial aid is money to help you pay for college or career training. It comes in the form of grants, scholarships, loans, work-study programs, or a combination. The aid comes from the federal and state governments, colleges and universities, banks, and private organizations.

Applying for financial aid is a separate process from applying for admission to a college or career training program. You must do both. For all government aid, and much private and institutional aid, you apply using the Free Application for Federal Student Aid, or FAFSA (see coming pages in this section for more details).

Four Primary Sources of Financial Aid

1. Pell Grants

Money provided by the federal government to college students who demonstrate financial need. Pell Grants do not need to be paid back. For the 2023-2024 FAFSA, the maximum Pell Grant is \$7,395*. To earn a Pell Grant, you must be a U.S. citizen or eligible noncitizen, and will need to complete the FAFSA (Free Application for Federal Student Aid).

2. Work-Study

This federally sponsored program provides students with part-time employment (often on campus) during college. Eligibility is based on financial need; students must complete the FAFSA for consideration.

3. Scholarships

Scholarships also don't need to be repaid, and are awarded for all sorts of activities, community involvement, hobbies, athletic abilities, and many other things. Students with exceptional academic grades can earn merit-based scholarships. Most scholarships require an application, and dollar amounts vary. Section 4 goes into detail about scholarship opportunities.

4. Loans

Various loans exist with many different repayment terms. All loans must be repaid with interest—similar to a car loan. Check out Student Loans and Parent Plus Loans in the Glossary for details.

*This amount may change every year

Two out of every three students receive some type of financial assistance.

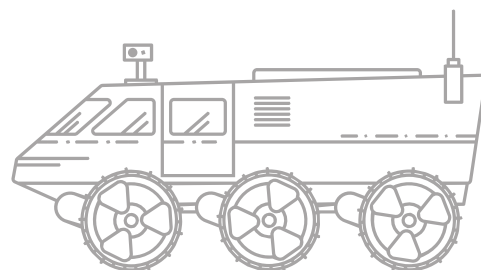

FAFSA (Free Application for Federal Student Aid) Facts

Filing the FAFSA is free. We've made it easy to gather needed information to complete the FAFSA. The FAFSA is an important part of your journey, and it might even mean free money to cover college costs.

The next few pages provide helpful forms and sample documents to get you through the three major steps to complete the FAFSA:

1. **Get your FSA ID (you and your parent), see pages 35.**
2. **Complete the FAFSA (with your parent), in the next pages, and the call-out box below for information on what documents you'll need.**
3. **Review your Submission Summary, at the end of the section.**

We've also included information to help you understand the financial aid award offers you receive from your college(s).

When you file the FAFSA, in addition to the information on the next page, you'll need the following information for you and your parent(s):

Bank Statements and Investments:

- Statements from all accounts (checking, savings, investments, etc.)
- Value of investment farms and businesses

Documents from 2 years prior to college start date

(For Example, if you plan to start college in the 2023-2024 school year, use 2021 documentation):

- Federal Income Tax Forms (e.g., 1040, 1040-NR, etc.)
- W2 forms
- Child Support paid or received (if applicable)
- Other benefits (workers' compensation, military, clergy, or veteran amounts)

Note that the FAFSA can automatically transfer information from federal tax returns that you or your parent(s) filed, through the IRS Direct Data Exchange (IRS DDX). If you receive the option to "Link to IRS" through FAFSA, choose that for automatic transfer of information. If you can't link to the IRS, you must manually enter the information. Regardless, keep the documents handy in case you need them to answer other financial questions.





SECTION 3

Pre-FAFSA Information

Fill out the following information to keep everything in one place. You'll need it to create your FSA ID and to complete the FAFSA.

- Your email (**not your high school email**): _____ cell phone: _____
Parent email: _____ cell phone: _____
- Are you a Nebraska resident? Yes No
If no, the month / year you moved to Nebraska: _____
- Are your parents Nebraska resident? Yes No
If no, the month / year your parents moved to Nebraska: _____
- Your Social Security number: _____ - _____ - _____
- Your parents' Social Security numbers (if your parent doesn't have a Social Security Number, use all 0's):
Parent 1: _____ Parent 2: _____
- If you are not a U.S. citizen, what is your permanent resident card A#: _____
- What are your parents' dates of birth? Parent 1 D.O.B. _____ Parent 2 D.O.B. _____
- Do you have a driver's license? Yes No
- Your driver's license #: _____ Expiration date: _____
- What is the month and year your parents were married, divorced, or separated? _____
- What is the highest level of school your parents completed? (Circle one for each parent).
Parent 1: Middle School / Jr. High High School College or beyond Other / unknown
Parent 2: Middle School / Jr. High High School College or beyond Other / unknown

<https://studentaid.gov/h/apply-for-aid/fafsa>

At <https://studentaid.gov/h/apply-for-aid/fafsa>, you can complete, submit, and track your application. If you do not have internet access, you can get a paper copy by calling 1-800-4-FED-AID (433-3243). Remember, filing the FAFSA is free. If you see a website or ad requesting a fee, steer clear!

You can also complete the FAFSA form using the myStudentAid app. Download the myStudentAid app in the Apple App Store (iOS) or Google Play (Android).

To learn more about how to complete the FAFSA correctly, visit <https://studentaid.ed.gov/sa/fafsa/filling-out>.



FSA (Federal Student Aid) ID Form

Before you complete the FAFSA, you must create an FSA ID (a username and password) to gain access to Federal Student's Aid online systems, and it will serve as your legal signature. Your FSA ID must be exclusive to you.

Fill in this form as you create your FSA ID, so you have the information when you need to log in later. To create an FSA ID, go to <https://studentaid.gov/fsa-id/create-account>

It's important to provide and verify your email address and cell number because those are the easiest ways to recover a password if you forget it... and that might happen.

You AND your parents must create an FSA ID to access the FAFSA. Therefore, it is important to keep them in a safe place. Your parents will need their FSA ID again if a child fills out the FAFSA later down the road.



Student Information

Email address (not your high school email):

Cell phone:

Username: _____ Password: _____

Date of birth: _____ Social Security number: _____ - _____ - _____

FAFSA Save Key: _____

Answer to Challenge Questions (answers are case sensitive):

Challenge Question	Answer

Parent Information (if applicable)

Email address: _____

Username: _____ Password: _____

Date of birth: _____ Social Security number: _____ - _____ - _____

Answer to Challenge Questions (answers are case sensitive):

	Answer

THIS INFORMATION SHOULD BE KEPT CONFIDENTIAL AND STORED IN A SECURE LOCATION!



SECTION 3

What Is My Dependency Status?

The following statements will determine your dependency status for the FAFSA. **Mark any that are true.**

<input type="checkbox"/> Will be 24 by January 1st of award year	<input type="checkbox"/> Are married (or separated but not divorced)	<input type="checkbox"/> Are working on a master's or doctorate degree
<input type="checkbox"/> Serve in the U.S. armed forces or are a veteran	<input type="checkbox"/> Since the age of 13 - had no living parent, were in foster care, or were a ward of the court	<input type="checkbox"/> Are an emancipated minor
<input type="checkbox"/> Have a court-ordered legal guardian	<input type="checkbox"/> Have children or dependents and provide more than half their support	<input type="checkbox"/> Are an unaccompanied youth who is homeless

If you marked any of the statements, you are independent and will not provide parental information on the FAFSA.

If none of the statements are true, you are a **dependent** student and must provide parental information on the FAFSA. Dependent students are required to include parent information. FAAs have the authority to change a student's status from dependent to independent in "unusual circumstances," read more at the Federal Student Aid website.

Parent Considerations

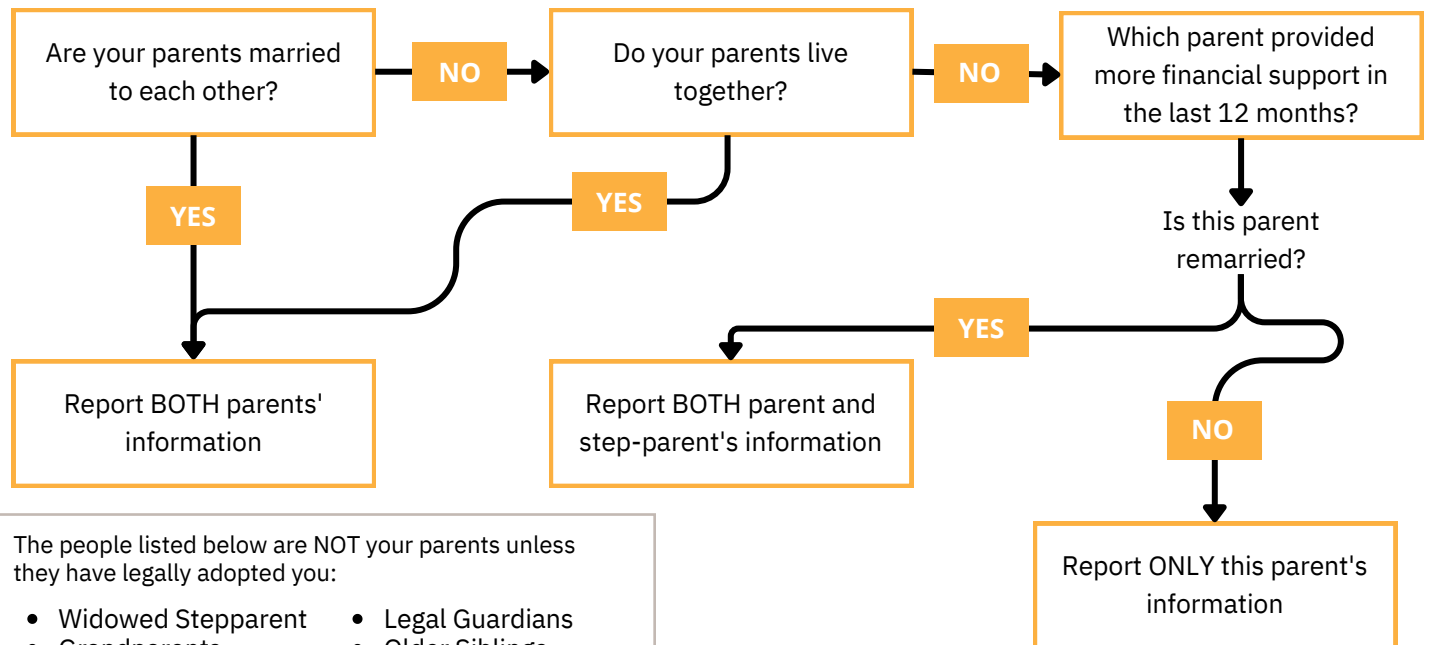

The people listed below are NOT your parents unless they have legally adopted you:

- Widowed Stepparent
- Grandparents
- Foster Parents
- Legal Guardians
- Older Siblings
- Aunts or Uncles

Source: Office of the U.S. Department of Education

FAFSA Submission Summary:

What is it, how do I get one, and why is it important?

What is the Submission Summary?

This report summarizes the information you submitted on your FAFSA and provides information about financial aid eligibility. A sample is shown on the next page.

How and when will I get my Submission Summary?

After you submit your Free Application for Federal Student Aid (FAFSA), you'll have access to your personal submission summary (within three days if you complete the FAFSA online; within 3 weeks if you mail the paper FAFSA).

Whether you receive your Submission Summary online or through the mail depends on whether you provide an email address on your FAFSA. If you provide a valid email address, you'll receive an email with instructions on how to access an online copy of your submission summary.

If you have a FSA ID (username and password) and your FAFSA has been processed, you can log in at fafsa.gov to view your summary information regardless of how you filed the FAFSA.

The school(s) you list on your FAFSA will have access to your SAR data electronically within a day after it is processed.

What information will it contain (and not contain)?

The Submission Summary won't provide exact amounts of financial aid, but it will provide a Student Aid Index (SAI), which will give you an idea of how much money you may have to come up with later. The estimated Pell Grant will be listed, too. If you cannot see this information, it means your application is incomplete, and you need to resolve any issues.

The Summary also contains a four-digit Data Release Number (DRN), which appears on the first page in the upper right corner of the paper and Acknowledgement. On the electronic Summary, the DRN is located in the box that contains the Application Receipt date, below the SAI. You will need the DRN if you choose to allow your college or technical school to change certain information on your FAFSA.

What am I supposed to do with my Summary?

When you get your Submission Summary, review it carefully to make sure it's correct and complete. Take a copy of it to your School Counselor to get help reviewing it. The school(s) you listed on your FAFSA will use Submission Summary information to determine your eligibility for federal—and possibly nonfederal—financial aid. A school may ask you to verify the accuracy of the data you provide on the FAFSA, so you need to be sure the information is correct.

If you don't have any changes to make to the information listed on your summary, just keep it for your records.

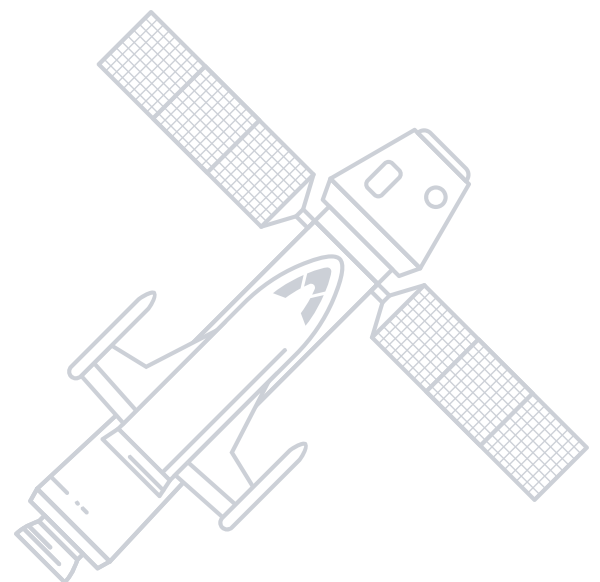



SECTION 3

Financial Aid Offers

After you've applied to your target schools and completed the FAFSA, you'll begin to receive financial aid award offers from each college.

You may receive your award offers through the mail, email, or online through your college student account. Review all offers carefully to ensure you understand your potential out-of-pocket expenses. Your School Counselor is a great resource here. It is also important that your parents / guardians review your award letter(s) to help you make this important decision. Financial award offers from colleges may vary greatly. As you review the awards, you'll want to consider your out-of-pocket costs for each university to help you make your decision on where you want to attend.

After you decide which school to attend, respond

to that school's financial aid offer. You'll be asked to "accept or decline" each component of your aid package. You can accept some offers, but decline others. Always accept "free" money—like scholarships and grants. Accepting work-study, if offered, is a good idea. There's no obligation at this point for work-study jobs, but accepting the award leaves your options open. Remember, all loans must be repaid with interest, so review terms closely before you accept loans. Unsubsidized loans grow interest as soon as you receive the money, but subsidized loans don't add interest until after college graduation (or if your enrollment falls below part-time), which can mean thousands of dollars difference. Note: if you don't graduate, you need to begin repayment within 6 months of leaving. See an example of an award summary below.

Financial Aid

Award Summary

Financial Aid Year 20XX-20XX

You are eligible to receive the awards listed below. Please review each award and corresponding message. You may Accept, Reduce and/or Decline any or all the awards that are currently available.

Awards - Academic Year						
Award Description	Category	Fall Offered	Spring Offered	Accept	Decline	Loan Details
Federal Pell Grant	Grant	3,000	3,000	<input type="checkbox"/>	<input type="checkbox"/>	
Federal Supp. Educ. Opp Grant	Grant	150	150	<input type="checkbox"/>	<input type="checkbox"/>	
State University Grant	Grant	2,750	2,750	<input type="checkbox"/>	<input type="checkbox"/>	
AZ Merit Scholarship	Scholarship	1,500	1,500	<input type="checkbox"/>	<input type="checkbox"/>	
Federal Work Study	Work/Study	1,500	1,500	<input type="checkbox"/>	<input type="checkbox"/>	
Direct Subsidized Stafford Loan	Loan	2,000	2,000	<input type="checkbox"/>	<input type="checkbox"/>	Loan Details
Direct Unsubsidized Stafford Loan	Loan	2,750	2,750	<input type="checkbox"/>	<input type="checkbox"/>	Loan Details
Awards - Totals		13,650	13,650	Academic Year Total:		\$27,300

Currency in US Dollars

[Cost of Attendance Summary](#)

What Is FAFSA Verification?

Each year, colleges and universities verify the accuracy of FAFSA for about 30% of students. The verification process typically requires that students and parents submit additional documents to the financial aid office at the college they will attend. The documents that may be requested include:

- tax transcripts or copies of tax returns
- birth or death certificates
- college enrollment forms from family members
- other forms / documents

How do I know if I was selected for verification?

First, as noted earlier, you can look at the top part of the Submission Summary where your SAI is shown. If there is an asterisk (*) next to the SAI, you were selected for verification.

The other option is to log onto your college student account. If you were selected for verification, you will see a notification, or your college may email you to let you know.

What if I was selected for verification?

1. Understand this process is routine. Most likely, you haven't done anything wrong on the FAFSA. It's just part of the process.
2. Check your college student account and / or college email to make sure your college received all the documentation they need. Also, confirm how they want you to send it (mail, email, online form, etc.).
3. Gather the documents you need. This may require you to ask your parents for copies of some documents or for you / your parents to contact the IRS office to request certain paperwork.
4. Submit all your paperwork as soon as you have it. You will not receive any aid if you do not complete this process.

Although this is a routine process, some students do not complete it for a variety of reasons. Some students have a hard time finding the documents requested, some have trouble getting documents from their parents, and some are confused by the jargon. If you get stuck, contact the financial aid office at your college. They are there to help.





What to Expect After Submitting Your FAFSA

Where does my FAFSA information go once I submit it? Your FAFSA information is shared with the financial aid offices of the schools you list on the application as well as your state's higher education agency to figure out how much aid you may receive.

How can I check to see whether my FAFSA form has been processed? You can check the status of your FAFSA form after submitting it online. You can check the status of a paper FAFSA form after it has been processed (roughly 7-10 days after the date mailed).

What happens after my FAFSA form is processed? You will receive a Submission Summary, which is a summary of the FAFSA data you submitted within three days to three weeks after you submit your FAFSA form.

What do I do if I'm told I've been selected for verification? If you've been selected for verification, don't assume you've done anything wrong. Your school is just checking to make sure your FAFSA data is correct. Some schools verify every student! Provide the documentation your school asks for to avoid delays in receiving your aid.

What if I made a mistake on my FAFSA form? How do I correct it? Once your application has been processed, you can correct your FAFSA form online or on paper. (Making corrections online is the easiest and fastest option).

Where do I see my financial aid offers? Once you decide on a college to attend, visit your college account's financial aid information section online to view offers included in your Submission Summary (like grants, work-study, or loans), as well as other institution or private aid you have been offered or awarded.

How do I decide what aid to accept, and how do I accept it? The rule is: free money first (scholarships and grants), then earned money (work-study), and then borrowed money (federal student loans). Decide what aid you really need and respond to the school's aid offer by their deadline.

How do I get my money? The financial aid staff at your school will explain exactly how and when your aid will be paid out. If you're receiving a federal student loan, you should expect to be required to sign a promissory note and go through entrance counseling.

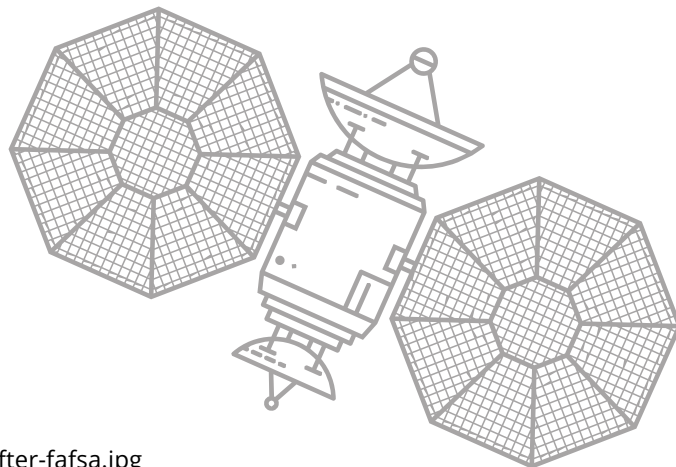

Source: <https://studentaid.gov/sites/default/files/what-expect-after-fafsa.jpg>



Section 4: Help with Lift-Off: Scholarships and Jobs

Scholarships and Jobs

Scholarships offer a great way to pay for college or career training, and you don't need to repay them. This section covers the different kinds of scholarships, how they work, and how to apply.

Since many scholarships are competitive, we'll offer advice on finding ones right for you and how to craft and submit your application, so you can maximize chances for landing the award.

In addition, a part-time job can help pay expenses. By filling out the FAFSA, you may qualify for a work-study job on campus, which could relate to your field of study. If you need more options, you can always find work off campus. We offer lots of tools and tips to help you apply for jobs in this section.



SECTION 4

Scholarships: Free Money Awaits

What is a scholarship?

Simply put, a scholarship is money to help pay for your education. Unlike loans, scholarships aren't repaid, and they are awarded for many things:

- Academic performance (also referred to as merit)
- Financial need
- Athletic performance
- Special talents and affiliations
- And more

Most scholarships require students to submit an application. The application may require an essay, a portfolio, a letter of recommendation or nomination by a teacher or School Counselor, or additional documents / creations. Please note that some scholarships require you to maintain a certain GPA throughout college, or else you could lose the funding, or worse, need to pay back the funds.

Where to Start

Most scholarship opportunities can be found online using search engines based on a personal profile you complete on the site.

Thousands of scholarships exist—from local to national —given by everyone from individuals to large companies. National scholarships get a lot of attention because they often offer large awards, but they're also very competitive. Go ahead and apply, but don't forget about local and state scholarships. Did you know you could be eligible for a scholarship simply based on the high school or church you attend, or even the town where you live? All awards add up, so apply for all the scholarships you can. When you apply to the three Nebraska public universities, your application also serves as a scholarship application for merit-based scholarships

****In order to get your scholarship dollars you must provide enrollment verification at your chosen postsecondary campus****



at those institutions. Most universities / colleges in Nebraska and across the country also administer numerous scholarships that require additional applications. To get you started, a list of scholarship websites and search engines is below.

Avoid Scholarship Scams

While you'll find plenty of scholarship opportunities, be aware of scammers. Here are some red flags to watch for:

- Winning a scholarship that you didn't apply for.
- Companies that request personal identification information, such as a Social Security number or bank account information.
- Scholarships that require a fee to apply.

If you're unsure about a certain company or opportunity, check with your School Counselor.



Check out these websites to help with your scholarship search.

- GIPS Scholarship Page
<https://www.gips.org/Page/1332>
- GIPS Foundation
<https://gipsfoundation.org/what-we-do/scholarships.html>
- EducationQuest Foundation Scholarships
<https://educationquest.org/pay/finding-scholarships/>
- The National Scholarship (DREAMers)
<https://www.thedream.us/scholarships/national-scholarship/>
- Midwest Student Exchange Program
<https://msep.mhec.org/>
- The Susan Thompson Buffett Foundation
<https://buffettscholarships.org>
- The Greater Grand Island Community Foundation
<https://www.gicf.org/scholarships>

Check your University's scholarship website for more!

Craft a Personal Statement

Many college and scholarship applications require an essay or personal statement. But it can be hard to know where to start. Here are some do's and don'ts for writing a memorable personal statement.

Highlight the personal & memorable

- **Do** choose a topic you're passionate about. This will help show what makes you unique.
- **Don't** focus on the great aspects of a particular college, the amount of dedication it takes to be a doctor, or the number of extracurricular activities you took part in during high school.
- **Do** share your personal story and thoughts.
- Take a creative approach and highlight areas not covered in other parts of the application, like your high school records.
- **Don't** cover too many topics. This will make the essay sound like a resume that doesn't provide any insight into your personality.
- **Do** focus on one aspect of yourself so the readers can learn more about who you are. Remember, readers must identify your main idea and follow it from beginning to end. Ask a parent or teacher to read your introduction and tell you what your essay is about.

Show, don't tell

- **Do** paint a picture with words. For instance, if you write about how one basketball game changed your life, include details about the bumpy leather ball, the smell of the locker room, or the reflection of the gym floor.
- **Don't** simply state a fact to get an idea across, such as "I like to surround myself with people with a variety of backgrounds and interests."

- **Do** include specific details, examples, and reasons to develop your ideas. For example, if you write about surrounding yourself with diversity, what does that look like? Who do you speak to, and how do they respond? What's the takeaway?

Use your own voice

- **Don't** use jargon like, "There is so much suffering in the world that I feel I have to help people." Avoid overly formal or business-like language, and don't use unnecessary words.
- **Do** write in your own voice. For example, you could write about a real experience that made you feel you had to take action. Remember, there may be 1,000's of applicants, but there is only one you! Talk about what is important to you and not what you think the admissions committee wants to hear.
- **Don't** plagiarize. Admissions officers will be able to tell.

Edit and proofread

- **Do** take time to edit and revise your essay.
- **Don't** rely only on your computer spell check. Pro tip: read your essay aloud. It will help you find errors.
- **Do** ask a teacher or parent to proofread your essay to catch mistakes. You should also ask the person who proofreads your essay if the writing sounds like you.

Adapted from: bigfuture.collegeboard.org

Write a Stand-Out Essay

Scholarship applications often require applicants to write a short (1–2 page) essay in response to specific prompts. Examples include:

- If you had the authority to change your school in a positive way, what specific changes would you make?
- Describe how you have demonstrated leadership ability both in and out of school.
- Pick an experience from your own life and explain how it has influenced your development.

The following tips can help you craft a stand-out essay. Don't forget your English teacher is a great resource.

Keep in mind all scholarships differ, so you will craft your essay specific to the requirements and expectations of the organization offering the award. Closely consider the question / prompt on the application and research the organization, so you can tailor your essay. Most important? Be yourself. Essays offer a glimpse of who you are and how you view the world.

Adapted from: estrellamountain.edu/students/scholarships/essay

Introduction (first paragraph)

Provide an overview of what you are going to talk about in the essay; be sure it is responsive to the essay prompt. If the essay is about you, give a brief description of your experiences, aspirations, family background, etc. Touch on why you want the scholarship.

Regularly use your CliftonStrengths and their resources for richer language in scholarship essays.



Body (paragraph 2–3)

Go into more detail on one of the topics listed in paragraph 1. For example, elaborate on your previous experiences, family and financial situation, volunteer work, employment, academic career, future goals, college plans, etc.

Conclusion (last paragraph)

Close your essay with a wrap-up of why you're the best candidate for the scholarship; how your goals match those of the organization. Avoid stating, "In conclusion..." and don't regurgitate what you wrote in earlier paragraphs.

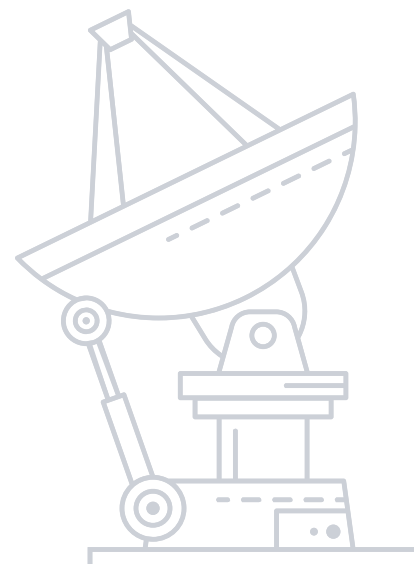

References and Recommendations

Many applications—from scholarships to jobs—require recommendations from people who know you. You choose who to ask, so think about those teachers, counselors, coaches, supervisors, or other adults who know you well, and ask them to write a reference letter for you. Depending on the application, recommendations may differ—from a phone call to a letter—so find out the details.

- Consider someone who can discuss your personal character, strengths, and challenges; someone who knows you and has experience interacting with you. If you need more than one person to serve as a reference for the same application, select individuals familiar with different aspects of your life (e.g., one teacher, your supervisor at work, and your soccer coach).

Who you might ask to serve as your reference:

- Always ask the individual ahead of time if they're able to recommend you. You do not want to miss an application deadline because the person was too busy to complete the recommendation process (such as answering surveys or writing a letter of recommendation). Give them at least two weeks' notice (three to four is even better).
- Provide the individual with a list of your honors, awards, athletic involvement, community service, and academic record as well as any other pertinent information. Giving the individual a copy of your resume is an efficient way to provide that information. If a specific form or format is required for a letter of recommendation, include any information they may need in an email.



Follow these tips for making the recommendation process smooth as possible for both you and your letter writers.

- Provide the individual(s) with the necessary instructions, forms, addresses, and / or stamped, addressed envelopes.
- Follow up with the individual to ensure they don't need any additional information from you.
- Always write a thank-you note to anyone who recommends you. Recommendations take time, and people put a lot of thought and effort into them. You do not want to take them for granted.

As a general rule, follow up at least one week before the letter is due. People can get busy, and it's a great way to remind them and see if they need any more information.

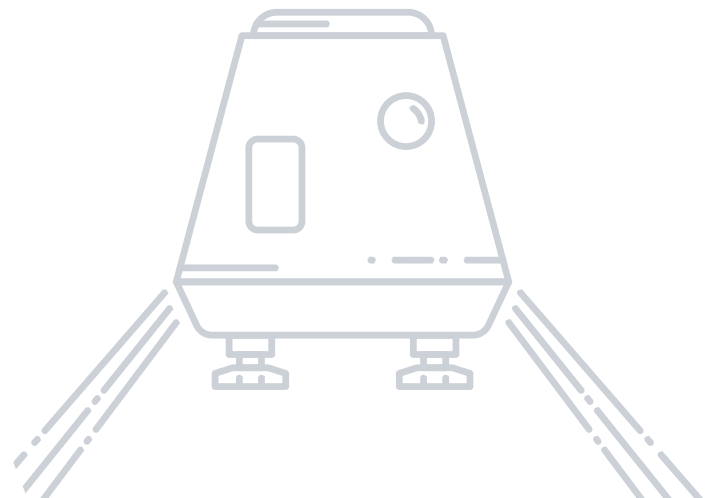



SECTION 4

Employment

Whether you plan to enter the workforce after high school or need extra work while in college, the following pages will help you apply for jobs.

Most jobs will require either a resume or application, and perhaps both. The next few pages will help keep you organized. You'll also find tips to create a resume and cover letter—and samples.

On the last page of this section, you will find a table for tracking your job applications—a helpful tool to ensure nothing falls through the cracks.

Tips on Getting a Job:

1. Get your paperwork in order

Most jobs will require a copy of a state-issued ID, Social Security card, and / or work permit so take these on interviews and your first day of work.

2. Consider your schedule and availability

As you transition to life after high school, your schedule, living situation, and access to transportation may change. Consider all these things before you apply for jobs, so they work with your current situation.

3. Search for jobs

Ask family, friends, professors, and others if they know of any job openings. Search for jobs online. If eligible for work-study jobs, find out where these jobs are posted. Your financial aid office may have pointers. Search for help-wanted signs in your neighborhood or on campus. Apply for more than one job.

4. Prepare for the interview

Research the organization before you go in for the interview.

- Practice interview questions.
- Prepare questions to ask during the interview.
- Dress professionally.
- Show up early to your interview.

Five questions you might want to ask in the interview:

1. Based on what you know about me so far, is there any reason you wouldn't hire me?

(This shows confidence. And, if they do have any reservations about you, this gives you an opportunity to address them.)

2. If I were offered this position, how would you measure my success, and what could I do to exceed your expectations? (This shows you're not afraid of being held accountable and that you want to exceed expectations.)

3. Can you tell me about the team I'll be working with? (This question will help you decide if you'll be happy working there.)

4. What do you like about working here? (This question allows the interviewer to connect with you on a more personal level, sharing their feelings. The answer will also give you insight into how satisfied people are with their jobs.)

5. What is the next step in the process? (This is the essential last question. It shows you're interested in moving forward and provides a time frame of when you'll hear back. Make sure to check back with the employer within the time frame.)





Resume and Job Application Information

Fill out the information below, so everything you need for all your applications is in one place. You can also use these details as the basis for your resume.

Full legal name: _____ Date of birth: _____

Citizenship: _____ If not a U.S. citizen, specify country: _____

If you are a Permanent Resident, Refugee, or Asylee, date of status approval / issuance: _____

Other visa type & date: _____

Driver's license number: _____

Permanent mailing address: _____

Current address, if different from permanent address: _____

Permanent phone number: _____ Cellular or message phone number: _____

Email address: _____

Social Security number: _____

High school academic history (if you attended more than one, list most recent)

Name of high school: _____ City, state of high school: _____

Dates attended: _____ Date of high school graduation (month & year): _____

Cumulative GPA: _____ ACT score: _____ SAT score: _____

Athletics, Clubs and Organizations				
Club / Sports Team	List your role / position each year			
	Freshman	Sophomore	Junior	Senior

College Courses		
Course Name	Date taken	Grade earned

Honors & Awards

Name and Date of Award	Reason for Award / Honor	Sponsor

Work Experience (list most recent examples first)

Start & End Date of Employment	Job Title	Company Name	Business Address	Brief Description of Duties

References

(Non-relatives who potential employers can contact to explore whether you would be a good hire)

Name	Title	Address (Street, City, State, Zip Code)	Phone Number	Email Address

Create a Resume

Content and format are equally important. If your work history is strong, but the format is difficult to read or contains typos, employers won't consider you. The example on the following page is clear, easy to read, and error-free.

Resume basics

- 1. Heading:** Include your name, address, email address, and phone number. Make it stand out and make an impression by using large, bold font. Make sure your email is professional (not `starwarsfan@hotmail.com` or `crzychik@aol.com`, for example).
- 2. Education:** List all degrees completed or in progress. As a high school student, include your GPA if it is 3.0 or above. List courses that reflect your work ethic and high aspirations, such as AP or dual enrollment courses, and relevant coursework for the job you're applying to. After college graduation, don't include high school information.
- 3. Experience:** Include your job title, the employer, the location (city and state, at minimum), and the dates of employment for each job listed. Include a brief description of your achievements / responsibilities. Ideally, paid work and unpaid work (community service) are listed separately.
- 4. Honors / Awards / Scholarships:** (Optional) Include the name of the organization that bestowed the honor / award and the date. Only include scholarships based on merit, not financial need.
- 5. Special Skills / Highlights:** (Optional) List any unique, relevant, or necessary skills not reflected in education or experience (e.g., foreign language fluency, computer program expertise, etc.).
- 6. References:** Ask permission first to list people as a references and provide them with a copy of your resume.

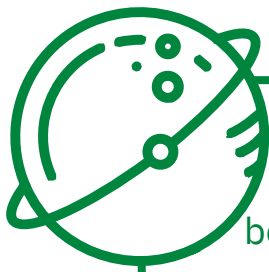

Some jobs may require a cover letter, and resources online can help you better display your communication style and personality in a professional tone.

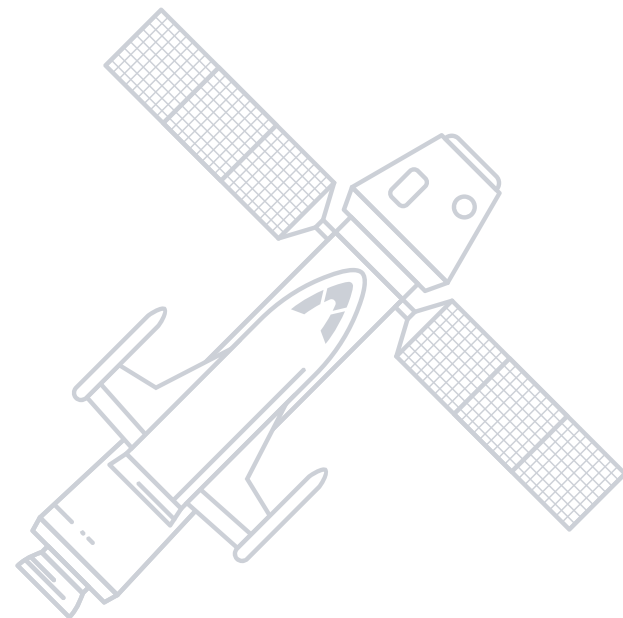



Sample Resume

EMILIA S. JONES

3328 West Parker Avenue, Mytown, Nebraska 68800
928-555-5555 | emily.jones@gmail.com

EDUCATION

May, 20XX High School Diploma with a 3.37 GPA, *ABC High School 333 S. School St., Mytown, NE*

SPECIAL COURSES

Spanish I –III ♦ Marketing I ♦ AP Chemistry ♦ AP Computer Science ♦ Word Processing

WORK EXPERIENCE

September 20XX – Present **Pharmacy Sales Associate, Walgreens, 123 Main St., Mytown, Nebraska**
·Duties include cashiering, customer service in English and Spanish, answering the phone and assisting or transferring callers as needed, general clean-up and other duties as assigned.

May – August 20XX **Order-Taker/Cashier, McDonald’s, 201 N. Country Dr., Mytown, Nebraska**
·Duties included accurately taking customer orders in English and Spanish, entering them into electronic order system, handling customer payments including providing correct change and handling credit card transactions.

EXTRACURRICULAR ACTIVITIES & AWARDS

20XX – current S.A.D.D. (Students Against Drunk Driving) – member 20XX – 20XX Club
R.I.F (Reading Is Fundamental) – secretary
20XX – 20XX Skyline Ambassadors (student service club) – member August 20XX “I Care”
Customer Service Award – McDonald’s

COMMUNITY SERVICE

St. Mary’s Food Bank – canned food drive, November 20XX, November 20XX
Sunday School Teacher – pre-school class, 20XX-20XX
Service Saturday – ABC High School, April 20XX

REFERENCES

Ms. Wonder Woman, History Teacher, ABC High School, (602)791-4808, wonder.woman@ABC.org
Mr. Ralph Peterson, Manager, McDonald’s, (928) 555-1555, r.pete@mcd.com

Tracking Community Service

Tracking Community Service									
Name of organization	Description of volunteer service	Dates of service	Number of hours of service	Take-aways: what you learned, enjoyed, experienced	Name of contact information (email, phone, website, & / or address)				

Tracking Scholarship Applications

Tracking Scholarship Applications										
Name of Scholarship	Components (items needed to apply e.g., essay, recommendations, transcripts, applications, nominator, etc.)	Value (amount) \$	Deadline	Notes	Date submitted	Date received and amount of award				
#1										
#2										
#3										
#4										
#5										
#6										
#7										
#8										
#9										
#10										

Tracking Job Applications



Tracking Job Applications								
Employer name	Role title / job description	Salary / rate	Link to job posting / application	Date applied	Contact name, number, email	Response	Interview date, time	Offer



SECTION 4

Notes for Scholarships and Jobs

Use this space to write down any additional notes and thoughts as you continue to apply to different programs.



Section 5: One Small Step, One Giant Leap: A Future in the Military

Join the Armed Forces

If you're interested in joining the U.S. military after high school, this section provides helpful resources. Time in the military can teach you a valuable trade; prepare you for a life-long career serving our country; or simply give you time to decide what you want to do next. It can provide valuable experience with good benefits and structure.

If you're not sure which branch to join, consider speaking with a recruiter in your area.

Before you become part of the military, you'll need to take the ASVAB test. In the coming pages, we've provided resources and websites to help you prepare.

Enlisting vs. ROTC

Military Recruiters

A military recruiter can help answer questions about service, providing a positive but realistic assessment of opportunities. A recruiter looks for qualified candidates for their respective branch, and provides information regarding military benefits. Your high school counselor can give you dates of when recruiters will visit your school.

ROTC Programs—an alternative to enlistment

ROTC stands for Reserve Officer Training Corps. It's a college program offered at over 1,700 colleges and universities across the United States that prepares young adults to become officers in the U.S. Military. In exchange for a paid college education and a guaranteed post-college career, cadets commit to serve in the Military after graduation. Each service branch has its own ROTC guidelines, and each university differs regarding availability. More information about ROTC is available on these websites:

- www.bestcolleges.com/resources/rotc-programs/
- www.todaysmilitary.com/education-training/rotc-programs

ASVAB

The Armed Services Vocational Aptitude Battery (ASVAB) is a multiple-choice test that determines enlistment qualification. Just like any other test, you should prepare for the ASVAB. Learn more about the ASVAB and how to prepare by visiting the sites below:

For general information:

- <https://www.officialasvab.com/>

For online ASVAB test prep:

- <https://www.march2success.com/>
- <https://asvabtutor.com/>
- <https://www.asvabpracticetests.com/>



If you are interested in enlisting in the military, the best, most up-to-date information can be found on the internet. Several helpful websites are described in this Section, along with the URL for each.

Delayed Entry Program

If you plan to join the military right after high school, you will likely enlist through the Delayed Entry Program (DEP) or the Future Soldiers Program in the Army. Simply put, you sign up before you're shipped out. DEP, visit the site below.

- <https://girightshotline.org/>

Military Career Opportunities

Military jobs vary greatly, yet each job is essential to the overall mission of defending our country. Explore all career opportunities, learn about compensation, and find out how to transition to the civilian sector:

- <https://www.todaysmilitary.com/careers-benefits>

Boot Camp Preparation

Physical and mental endurance play an important role in basic training, so if you prepare now, you'll gain confidence. If you neglect preparation, get ready for an uphill battle. Training for each branch differs, so learn more about differences and learn preparation tips below:

- <https://www.military.com/military-fitness/army-basic-training/getting-prepared-for-bootcamp>
- <https://breakingmuscle.com/fitness/how-to-prepare-your-mind-and-body-for-basic-training>

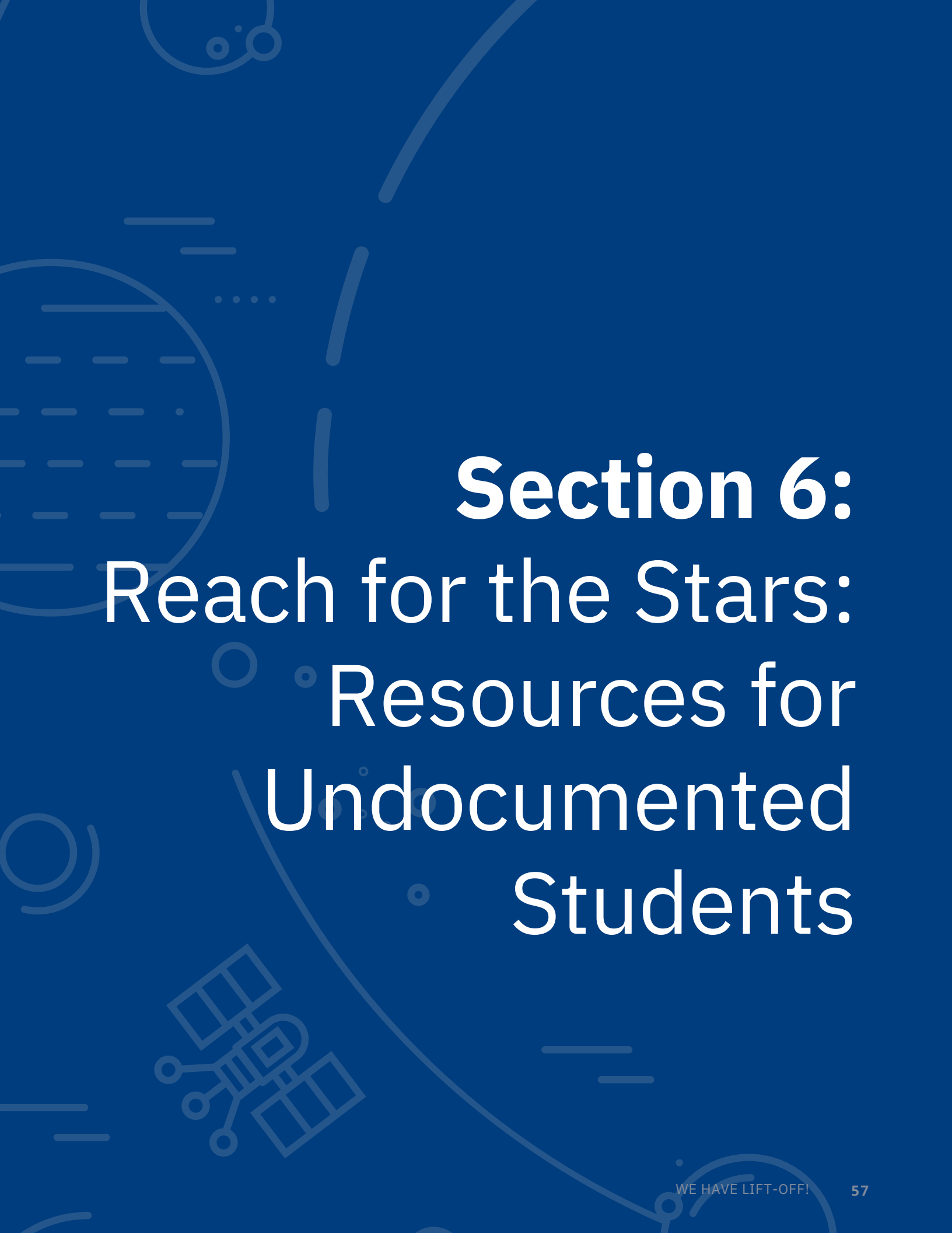
The background is a solid blue color with faint, light blue line art illustrations of space-related objects. On the left, there is a stylized planet with horizontal lines representing latitude. In the bottom left, a satellite with solar panels is shown. Various curved lines and dots are scattered across the page, suggesting orbits or stars.

Section 6: Reach for the Stars: Resources for Undocumented Students



A Pathway to College for ALL Students

If you want to continue your education beyond high school, your documentation status shouldn't hold you back. A university, community college, or technical school education is within your grasp if you're undocumented. However, the process to get there may differ from other students.

While answers about residency, tuition, and eligibility for specific scholarships are not always simple, this section provides general information on resources available to help you find a school and pay for your education.

Terms to Know

Deferred Action for Childhood Arrivals (DACA) Program:

A kind of administrative relief from deportation. The policy allows youth under 31 years old as of June 15, 2012, who came to the United States before the age of 16 without documentation, and have been educated by U.S. school systems, the opportunity to remain in the U.S. by following specific guidelines. The DACA program has undergone changes since it was created. For up-to-date information on DACA, visit uscis.gov and search the site for "DACA."

A term used to indicate the documentation status of a person who applied and received relief from deportation through DACA.

DREAMers: Individuals who would have qualified under the DREAM Act are often referred to as DREAMers. The term has been used to refer to individuals in the U.S. who were brought to the country at an early age without documentation but have assimilated to the U.S. culture and have been educated by U.S. school systems. At this time, this term does not define a documentation status, but instead, it is sometimes used to define an identity or a community. Students who are undocumented and students who have DACA status may both identify as DREAMers, or may choose not to. Some people do not use the term DREAMer because it separates young undocumented immigrants who entered the country as children from other immigrants, further marginalizing some immigrants.

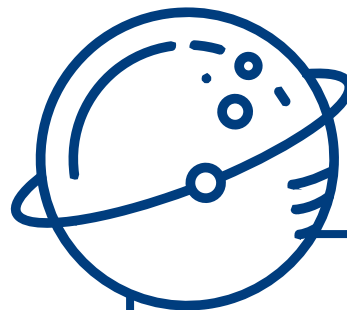

Public Universities can often have separate funds for DREAMers. Thoroughly search through their resources for any scholarships that may best suit your situation.

Four Things You Need to Know about College



If you're a high school student who's undocumented—that is, you were born outside the United States and you're not a U.S. citizen or legal resident—you probably have a lot of questions about going to college. Here are some important facts.

1. You can go to college

The first thing you should know is that no federal law prevents U.S. colleges from admitting undocumented students. And only a few states have placed any kind of restrictions on undocumented students attending public colleges and universities. In most cases, colleges set their own rules for processing students and determining residency status, so you should research the policies of the colleges you are interested in attending.

Undocumented students cannot receive federal financial aid for college—the type of aid on which many college students rely. However, undocumented students can get financial aid or scholarships for college in other ways. This is covered under the heading "Undocumented Students: Questions and Answers about Paying for College" later in this section.

2. You are not alone

You're the one who will have to put in the work it takes to get to college—but building a support network is key. Start with your family. Make sure

they know you want to go to college. Talk with them about your options for choosing a college and paying for your education.

You can also seek advice from trusted teachers and counselors at your high school. Along with giving you guidance, they might be able to put you in touch with other undocumented students who have successfully enrolled in college or with college admission counselors who can help you.

If you're worried about telling teachers and counselors that you're undocumented, be aware that, by law, school officials cannot disclose personal information about students—including their immigration status.

3. You can find a college that fits you

As you look for colleges that match your wants and needs, you might want to find out if the colleges you're interested in have programs, student organizations, or centers that support first-generation immigrant students. You may consider applying to private colleges, rather than public institutions. Reviewing college websites and publications is a good place to start.

4. You can find resources to help you

This section of the guide will provide you with general information on paying for college, filing the FAFSA as a DACA recipient, and applying for one of the three public universities in Nebraska. The majority of the information in this section comes from bigfuture.collegeboard.org. Visit this website for more information.

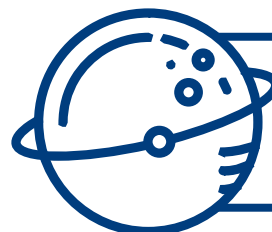

You CAN attend a Nebraska college or university.



Questions and Answers about Paying for College

- Do colleges offer financial aid or scholarships to undocumented students?**
Yes, some do. Private colleges often have special funds available. Regardless of immigration status, some public colleges and universities also award scholarships to students. Some universities may ask you to complete the CSS/Financial Aid PROFILE instead of a FAFSA. Check with the admission or financial aid office at each college you are interested in to find out its requirements.
- Am I eligible for scholarships?**
Yes, you just need to find ones that you qualify for. Start by talking to your Counselor and searching for scholarships available for undocumented students. This Guide includes a list of pages where you can begin your search. There are many scholarship opportunities, and some private scholarship organizations allow undocumented students to apply. There are even a few scholarships specifically for undocumented students. Be sure to look into local scholarships offered by community groups that might be open to all students living in the local community.
- Can I get federal financial aid?**
No. You can't get federal financial aid unless you're a U.S. citizen or eligible noncitizen. This means you should not fill out the Free Application for Federal Student Aid (FAFSA). Unless a College specifically asks for you to do so.
- Can I get a Pell Grant?**
No. Pell Grants are a type of federal financial aid.
- Can I get financial aid from my state?**
No, Nebraska does not offer financial aid to undocumented students.
- Do I pay the in-state or out-of-state rate at a public college in Nebraska? What about in a different state?**
Many public colleges and universities charge out-of-state tuition to undocumented students, which can cost more than double regular fees; however, in Nebraska, undocumented students have access to in-state tuition. Since policies from college to college differ, you'll want to contact each institution to find out what you qualify for. In some cases, private colleges or out-of-state colleges make good financial aid offers, so it's important to carefully review all your financial aid awards.

Check out these websites to help with your scholarship search.

- Nebraska Appleseed Resources
<https://neappleseed.org/20445>
- UNL: Undocumented and DACA Student Resources
<https://www.unl.edu/oasis/undocumented-and-daca-resources>
- UNO Dreamer's Pathway Scholarship
<https://www.unomaha.edu/student-life/achievement/academic-and-career-development-center/dreamers-pathway.php>
- Commission on Latino-Americans
<https://latinoac.nebraska.gov/education.htm>
- College Scholarships for DACA and Undocumented Students
<https://www.bestcolleges.com/resources/undocumented-students/scholarships/>
- College of Saint Mary: Scholarships
<https://www.csm.edu/admissions/scholarships-grants>
- The Dream.US
<https://www.thedream.us/scholarships/>



The background is a solid orange color with various white line-art icons. At the top left, there's a planet with horizontal lines. In the center, a satellite with solar panels is shown. At the bottom left, there's a stylized sun or moon with concentric circles. Scattered throughout are stars, dots, and curved lines representing orbits or trajectories.

Section 7:

How to Decide

I'm uncertain about plans after high school.

That's okay. It's a lot to think about, and doubts are common—even for students with solid postsecondary plans. Creating a plan won't lock you into one career path forever, but it will provide guidance as you move into your future. Think of it as a roadmap of sorts. You may experience a side trip or two, but with a destination in mind, you're more likely to get there.

Review the following pages to help map out plans after high school.

You probably know this already, but here are some options:

- University
- Community College / Transfer
- Technical Program
- Military
- Workforce / Apprenticeship

One last thing before we start. Don't worry about having everything figured out. You may know you want to go to community college, but have no idea what you want to study. You can decide that later with the help of Sections 2-6 in this Guide. It'll all come together.

So, let's get started!

How do you decide which option holds the most promise for you after high school?

Approach decision making in stages:

- 1) **Dream:** envision your ideal life;
- 2) **Explore:** imagine careers that 'fit' the unique you;
- 3) **Plan:** discover the 'pathway' to your desired career, and:
- 4) **Assess:** take stock of where you are to refine and decide on the best route forward.

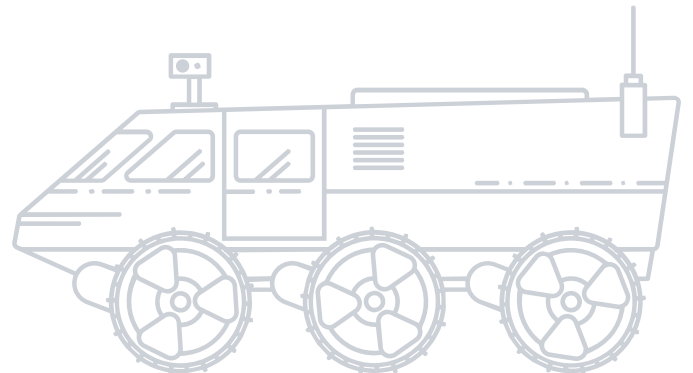

Stage 1 – Dream

First, we encourage you to dream. How do you envision your ideal life? Consider:

- What kind of lifestyle do you want?
- How do you want to spend your time?
- How might you use your interests and talents in an ideal job?
- What could you do to make the world a better place?
- How do the desires and needs of your family factor into your future happiness?

Give yourself the freedom to dream big about your future.

Considerations	Your Answer	Implications for Career Choice
Would you prefer to engage with people in your everyday work life, or do you prefer to work alone as much as possible?		
Is a high salary important? Think about how expensive your hobbies and pastimes are, how many family members you expect to support, and other lifestyle considerations.		
What kind of work-life balance do you want?		
Would you prefer to work in a climate-controlled environment or outdoors?		
Do you prefer being physically active, or would you like a desk job?		
Do you like to travel, even if that means being away from loved ones at times?		
How important is it that your work is meaningful? Is it important to "make a difference" in the world / your community?		
Consider family influences: A) Is it important to you to take over a family business / farm, follow in your parent's footsteps, or pursue a career that your parents want for you? B) Do you want to forge your own path regardless of family opinions? C) Or, are you and your family's desires the same?		

Stage 2 – Explore



Check MyNextMove.org for job insights, skills, and education info!

The exploration phase is exciting because you get to think about all your strengths and skills, and what you want to learn in the future. Think of your current interests as a starting point, and remember, you will gain many more interests and skills in your life.

You have already completed stage 2 of exploring a pathway that suits you through discovering the pathway that focuses on your interests. Luckily for you, high school pathways are a great way to explore a career before commitment. As you think about your career options, think about your interests, passions, and the work environment you prefer. If you lead with this, it will increase your long-term satisfaction. Don't worry too much about an actual job because we know many future jobs don't even exist today.

Now fill out **your** profile:



Likes:

Strengths:

Causes you care about:

Cultural / personal considerations:

Possible careers:

Stage 3 – Plan

Stage 3 requires you to make a plan to get the training, experience, or credential needed for the career path of your choice. To assist you, the next few pages provide information on:

1. Types of careers, credentials and paths, and;
2. Earning potential by degree.

Credentials / Educational Pathways

Search online for the credentials / education needed for each of the career areas you are interested in, then mark an "x" in the table below to indicate the path that most interests you in getting there.

Career Examples*	Credential Needed	Where to obtain ("Path")	My Path
Teacher, Architect, Marketing Manager, Engineer, Registered Nurse, Journalist, Computer Programmer, Software Developer	Bachelor's Degree—a credential earned by a college student after a specified course of study, which usually takes four years.	Four-Year University or College	
Web Developers, Paralegal, Mechanical / Industrial Engineering Tech, Occupational Therapy Assistant, Air Traffic Controller	Associate degree—a credential granted by a community or junior college to a student after completing a specified course of study, which takes about two years, full-time.	Community College	
Dental Assistant, Motorcycle Mechanic, Electrician, HVAC Tech, Massage Therapist, Welder, Cosmetologist	Certificate—This credential is awarded to individuals who complete a defined set of requirements and coursework.	Community College or Technical Institute	
Carpenter, Plumber, Machine Operator, Construction Worker, Dog Trainer	Apprenticeship / Work Experience—This requires on-the-job training from a trade master to learn essential skills and qualifications, which can take 1-5 years.	Through an employer, either on the job, or through a designated apprenticeship program	
Lawyer, Doctor, Veterinarian, Dentist, Orthodontist, Pharmacist	Professional Degree—a credential awarded to students by specialized postsecondary institutions after completing a rigorous course of study and fulfilling other requirements.	Professional School (e.g., Law School, Medical School, Dental School) after completing a bachelor's degree	

* Note that some individuals performing these jobs may have different credentials. These examples are generalizations.

Stage 4 – Assess

Congratulations! All your hard work in previous sections helped you get a plan in place. This will provide direction and set you on a path right for you. In Stage 4, you'll learn how well-prepared you are, so you can proceed or make some adjustments. Either way, your plan keeps you on track. So, let's get started.

Pick the Path

On the next page, identify your first choice of pathways (A, B, C, D, E) and then fill out the corresponding questionnaire. If you find you are missing some requirements, meet with your School Counselor to see if you can catch up before you graduate. Don't worry if you can't complete the prerequisites before you graduate. That only means you'll need to take a different first step. You can still reach your ultimate goal—it just may take a little more time. For instance, if you want to earn a bachelor's from a university, but your grades don't meet minimum qualifications for admission, you may first begin at a community college, and then transfer to a university once you've established a strong GPA.

What pathway did you select in Stage 3?

Pathway Selected

You Picked:	Go to the Assessment Marked:
<p>University / Bachelor's Degree (Professional degrees for dentists, attorneys, and doctors require a bachelor's first.)</p>	<p>A</p>
<p>Community College / Associate degree</p>	<p>B</p>
<p>Technical School / Certificate</p>	<p>C</p>
<p>Apprenticeship / Work Experiences</p>	<p>D</p>
<p>Military was not listed, but that's what I want to do!</p>	<p>E</p>

A University Readiness Assessment

If you plan to attend a four-year university to pursue a bachelor’s degree, this assessment tool is for you! The questionnaire will help you find out if you’re ready to go. Don’t worry if you circle a lot of “no’s.” That just means you may want to start off at a community college and then transfer to a four-year university to complete your bachelor’s degree. We’ll give you more info about that, too, at the end of the assessment.

Graduation Status

I have enough credits to graduate "on-time." Yes No

I passed all classes required for graduation. Yes No

If I answered “no,” what steps must I take as a high school senior to get to “Yes?” _____

Academic Preparation

I have passed all classes required for university admission. Yes No

My unweighted GPA meets the admission requirement for my program(s) of choice. Yes No

My ACT or SAT score meets the admission requirement for my program(s) of choice. Yes No

If I answered “no,” what steps must I take as a high school senior to get to “Yes?” _____

General Admission Requirements for ASU, NAU, and UA		
High School Courses	GPA / Rank	Other / Testing
<ul style="list-style-type: none"> • 4 years of English • 4 years of Math (starting at Alg 1 or higher) • 3 years of Science with lab • 2 years of Social Science • 2 years of the same second language • 1 year of CTE or fine arts 	<ul style="list-style-type: none"> • 3.0 or higher in core academic courses • Graduate in top 25% of your class 	<p>College entrance exams are not required for admission, but are recommended for merit-based scholarships and to supplement your application if other requirements were not met. Check the universities’ websites for target scores on ACT / SAT.</p>
<p style="text-align: center;">Interested in other universities?</p> <p>Each four-year university sets its own admission requirements, so it’s important to research requirements for all universities you’re interested in attending to make sure you’re on track. Check college websites and contact admission counselors to learn about admission requirements, specific program requirements, any exceptions, and the admissions process.</p>		

University Admission

I know the university admission requirements for all my selected schools. Yes No

I know the application deadlines for all my selected schools. Yes No

I know the application deadlines for all my selected schools. Yes No

If I answered “no,” what steps must I take as a high school senior to get to “Yes?” _____

Program of Study

The universities I’m interested in offer the major I am interested in. Yes No

I know and meet any specific / special requirements for my major. Yes No

I understand the pros and cons of entering college with an “undeclared” major. Yes No

If I answered “no,” what steps must I take as a high school senior to get to “Yes?” _____

Financial Preparation

I know how much it will cost to attend my chosen university. Yes No

I know how I will pay for college. Yes No

I know and can meet the FAFSA priority deadlines for the universities I am interested in. Yes No

I have registered on scholarship search engines and / or applied for scholarships Yes No

If I answered “no,” what steps must I take as a high school senior to get to “Yes?” _____

If you’re missing some requirements, meet with your School Counselor to see if you can still complete them before you graduate. Once you’ve turned any nos to yeses or have a plan to before graduation, you’re ready to launch your plan, so you can use the Guide to stay on track.

Don’t worry if you’re unsure if you’ll be ready to attend a four-year university right after high school. That just means you may need to start off at a community college first and then transfer to a four-year university for your bachelor’s. If this is the case, head to the next assessment.

SECTION 7

B Community College Readiness Assessment

If you plan to complete an associate degree, a certificate, or the foundation courses for a bachelor's degree at a community college, this assessment tool is for you! Most students attend the community college closest to their hometown, but a few community colleges in Nebraska have on-campus housing so students from farther away can attend, too.

Graduation Status

I have enough credits to graduate "on-time." Yes No

I passed all classes required for graduation. Yes No

If I answered "no," what steps must I take as a high school senior to get to "Yes?" _____

Academic Preparation

I have passed all classes required for university admission. Yes No

My ACT or SAT score is high enough for university admission or scholarships. Yes No

If the answers to the two questions above are "Yes," do I understand the benefits and accessibility of attending a four-year university next year? Yes No

If I answered "no," what steps must I take as a high school senior to get to "Yes?" _____

Community College Awareness

The community college offers the major I am interested in or the general education courses to transfer to a university to pursue my major. Yes No

I am aware of the enrollment steps (including applying, taking a placement test, and / or registering) at the community colleges that interest me. Yes No

I understand the pros and cons of entering college with an "undeclared" major. Yes No

If I answered "no," what steps must I take as a high school senior to get to "Yes?" _____

B Community College Readiness Assessment

Financial Preparation

I know how much it will cost to attend the community college. Yes No

I know how I will pay for college. Yes No

I know, and can meet, the FAFSA priority deadlines for the colleges I am interested in. Yes No

I have registered on scholarship search engines and / or applied for scholarships. Yes No

If I answered “no,” what steps must I take as a high school senior to get to “Yes?” _____

If your assessment indicates that you are missing some requirements, meet with your School Counselor to see if you can still complete them before you graduate.

Your goal is to have answered "Yes" to most of these questions or to have set up a plan on how you will get to "Yes" before you graduate high school. Note that if you answered "Yes" to the questions under academic preparation, it's likely that you could be admitted and could succeed at a four-year university. If you think you may want to attend a four-year university, complete the assessment **A** in this section. Either way, use the resources in the rest of this Guide to help you complete all the steps you'll take before graduation!

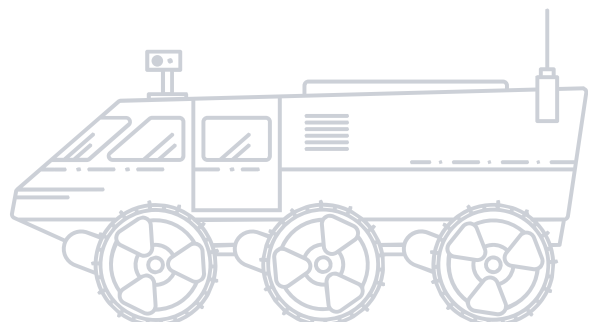

SECTION 7

C Technical School Readiness Assessment

If you want to earn a certificate at a technical school, this assessment tool is for you!

Graduation Status

I have enough credits to graduate "on-time." Yes No

I passed all classes required for graduation. Yes No

If I answered "no," what steps must I take as a high school senior to get to "Yes?" _____

Academic Preparation

I have passed all classes required for university admission. Yes No

My ACT or SAT score is high enough for university admission or scholarships. Yes No

If the answers to the two questions above are "Yes," do I understand the benefits and accessibility of attending a four-year university next year? Yes No

Does my local community college offer the certificate I want? Yes No

If the answer to the question above is "Yes," would attending the community college be the best route? Why or why not?

If I answered "no," what steps must I take as a high school senior to get to "Yes?" _____

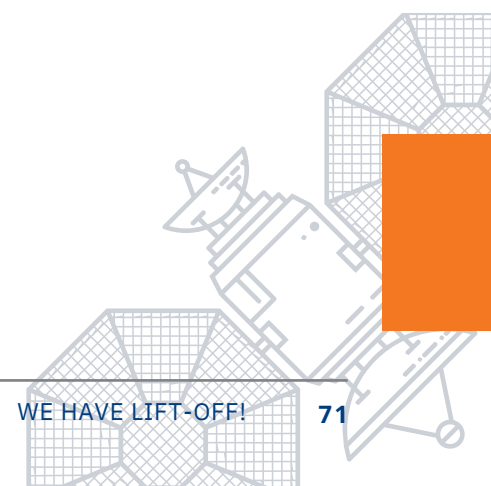

C Technical School Readiness Assessment

Technical School Admission Process

I understand the admissions process for my selected school (interviews, entrance exams, portfolios, application deadline). Yes No

I know and meet any specific / special requirements for my field of study. Yes No

If I answered “no,” what steps must I take as a high school senior to get to “Yes?” _____

Financial Preparation

I know how much it will cost to attend the technical school that interests me. Yes No

I know how I will pay for my certificate program. Yes No

I know, and can meet, the FAFSA priority deadlines for the schools I am interested in. Yes No

I have registered on scholarship search engines and / or applied for scholarships. Yes No

If I answered “no,” what steps must I take as a high school senior to get to “Yes?” _____

If your assessment indicates that you are missing some requirements, meet with your School Counselor to see if you can still complete them before you graduate.

Hopefully, you answered “Yes” to most of these questions or set up a plan to get to “Yes” by the time you graduate from high school. If you answered “Yes” to the questions under academic preparation, it’s likely you could attend and succeed at a four-year university or community college. Often, community colleges cost less than technical schools. If you think you may want to attend a four-year university or a community college, complete the appropriate assessments (**A** or **B**).

If you are still interested in attending a technical school, use the resources in the rest of this Guide to help you complete all the steps you’ll take before graduation!

SECTION 7

C Apprenticeship / Work Readiness Assessment

If you plan to do an apprenticeship or enter the workforce immediately after high school, this assessment tool is for you!

Graduation Status

I have enough credits to graduate "on-time." Yes No

I passed all classes required for graduation. Yes No

If I answered "no," what steps must I take as a high school senior to get to "Yes?" _____

Academic Preparation

I have passed all classes required for university admission. Yes No

My ACT or SAT score is high enough for university admission or scholarships. Yes No

If the answers to the two questions above are "Yes," do I understand the benefits and accessibility of attending a four-year university next year? Yes No

The reason I want to enter the workforce immediately after high school is: _____

I understand that community colleges have "open admissions" so that even with a low GPA, I could enroll there to obtain a trade / technical certificate. Yes No

If I answered "no," what steps must I take as a high school senior to get to "Yes?" _____

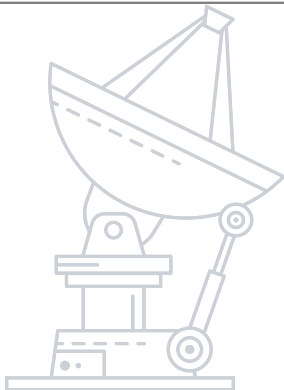

Apprenticeships involve on-the-job training and often additional studies to earn professional certification. Some occupations include healthcare, skilled trades like electrician, information technology, cyber security, advanced manufacturing, and business services.



Workforce Entry Process

I have a resume. **Yes** **No**

My ACT or SAT score is high enough for university admission or scholarships. **Yes** **No**

If the answers to the two questions above are “Yes,” do I understand the benefits and accessibility of attending a four-year university next year? **Yes** **No**

The reason I want to enter the workforce immediately after high school is: _____

Financial Preparation

I understand significant financial aid is available to pay for college, but I still prefer to enter the workforce after high school graduation. **Yes** **No**

If your assessment indicates that you are missing some requirements, meet with your School Counselor to see if you can still complete them before you graduate.

The goal is to answer “Yes” to most of these questions or set up a plan to get to “Yes” by the time you graduate. If you answered “Yes” to the questions under academic preparation, it’s likely you could attend and succeed at a four-year university or community college before entering the workforce. So, if you’ve changed your mind, check out the assessments on previous pages.

If you still want to enter the workforce right away, use the rest of the guide to keep you on track.

SECTION 7

C Military Readiness Assessment

If you plan to enlist in the military, this assessment tool is for you! If you have decided to join the military by way of attending a military academy, or through ROTC, then complete the four-year university assessment **A**. Otherwise, use this assessment.

Graduation Status

I have enough credits to graduate "on-time." Yes No

I passed all classes required for graduation. Yes No

If I answered "no," what steps must I take as a high school senior to get to "Yes?" _____

Academic Preparation

I have passed all classes required for university admission. Yes No

My ACT or SAT score is high enough for university admission or scholarships. Yes No

If the answers to the two questions above are "Yes," do I understand the benefits and accessibility of attending a four-year university next year and the ROTC option? Yes No

The reason I want to enlist in the military after graduation is : _____

I understand that community colleges have "open admissions" so that even with a low GPA, I could enroll there to obtain a trade / technical certificate. Yes No

If I answered "no," what steps must I take as a high school senior to get to "Yes?" _____

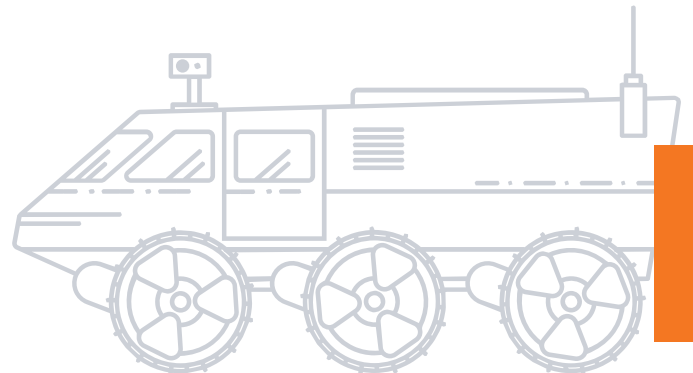

E Military Readiness Assessment

Military Enlistment Process

I understand the enlistment process for my selected branch of the military **Yes** **No**

If I answered “no,” what steps must I take as a high school senior to get to “Yes?” _____

Based on my current ASVAB scores, should I retake the assessment? **Yes** **No**

My ASVAB Score(s): _____

Financial Preparation

I understand significant financial aid is available to pay for college, including ROTC programs, but I still prefer to enlist in the military after high school graduation. **Yes** **No**

If I answered “no,” what steps must I take as a high school senior to get to “Yes?” _____

If your assessment indicates that you are missing some requirements, meet with your School Counselor to see if you can still complete them before you graduate.

If you answered “Yes” to the questions under academic preparation, it’s likely you could attend and succeed at a four-year university or community college before enlisting in the military. So, if you’ve changed your mind, check out the assessments on previous pages. If you are interested in joining an ROTC program at a four-year university, complete the assessment marked **A**. If you have considered all your options and decide that enlisting in the military is your goal, use the resources in the rest of this Guide to help you complete all the necessary steps before graduation!

Section 8: Glossary

Glossary

There are a lot of acronyms and college terminology that can be confusing. Here are a few that you might be wondering about. If there's one you don't see listed here, check with your School Counselor for assistance.

U

Tr

Cc

Ti

M

W

2+2 / 3+1 programs: A postsecondary pathway in which students begin at the community college where they complete general educational requirements over 2 or 3 years and then transfer to a university (for the remaining 1 or 2 years) to complete a bachelor's degree.

ACT / SAT: Standardized college entrance exams. Many colleges and universities require ACT or SAT scores as part of the application process.

Advanced Placement (AP): College-level courses offered at high school in which a student has the opportunity to earn college credit, advanced college course placement, or both.

Admission: Notification from the college to which you applied that you are accepted. Students must respond, by the given deadline, to inform the college if they will accept the offer. Students accepted to multiple schools will want to compare their financial aid packages to help them decide which school to attend.

Advisor: A college staff member or professor who helps a student plan and complete a course of study at a college or university.

Application: A form that must be filled out to be considered for entry into university, community college or technical school. Scholarships and job openings may also require applications.

Apprenticeship: Registered apprenticeships provide the opportunity to "earn while you learn." Partnerships between trade organizations, employers, state government, and community colleges provide a program that combines classroom training (which may include college credit course) and paid, supervised on-the-job training, lasting 2-5 years. After successful completion of an apprenticeship program, students are eligible for certificates of completion and / or licenses for specific occupations and trades.

Nebraska high school graduation requirements: The minimum subject credits required to graduate from high school: English – 4; Math – 3 (4 for University); Science – 3; Social Studies – 3; (varies by district).

Associate degree: A degree granted after successful completion of a course of study requiring approximately 60 credits, typically by a community or junior college. Full-time community college students taking 15 credits per semester can generally finish an associate degree in two years (also known as AA or AS degree, short for Associate of Arts and Associate of Science).

ASVAB: A test to determine qualification for enlistment in the U.S. Armed Forces. It stands for Armed Services Vocational Aptitude Battery.

Award Letter: Notice from a school of the amount and type of financial aid that the school can provide a student.

Bachelor's Degree: A degree earned for a course of study that normally requires 120 to 130 credits, involving specific classes related to the student's major. Full-time students ideally complete a bachelor's degree in four-years, although changing majors, transferring institutions, taking fewer than 15 credit hours per semester, and / or taking courses that don't count toward one's declared major, can lengthen the time commitment (also known as BA or BS, short for Bachelor of Arts and Bachelor of Science).

Certificate: An official document that attests to a particular accomplishment. In the postsecondary world, these certifications may require a series of courses, internships, and tests before a student can work in that field. Examples include welding, medical technology, auto mechanics, massage therapy, and court stenography.

CLEP: The College Level Examination Program (CLEP) is a group of standardized tests created and administered by the College Board. These tests assess college-level knowledge in 36 subject areas and provide a mechanism for earning college credits without taking college courses.

Community College: A public postsecondary institution that offers courses to residents in the surrounding area. Students may attend community colleges to obtain associate degrees or technical certificates, or may take courses there towards a

bachelor's degree, before transferring to a four-year university (2+2 or 3+1 pathway). Students can also take courses to enhance their skills in an area or just for fun.

Cost of Attendance (COA): The total cost of going to college, including tuition, fees, room and board, books, transportation, and personal expenses.

Course of Study: Group of courses students are required to take in order to earn a college degree; a major.

Credit or Credit Hour: Points awarded for successful completion of high school or college courses. College credit hours usually equal the number of hours a class meets per week.

Deferment: A period in which payment is not required. In the postsecondary realm, students can obtain deferment on paying their enrollment deposit as well as on paying interest and / or principal on student loans. Deferments do not last forever. Eventually, these payments must be made.

Deferred Action for Childhood Arrivals (DACA) Program: A kind of administrative relief from deportation. The policy allows young children (under the age of 16) who came to the U.S. without documentation and have been educated by U.S. school systems, the opportunity to remain in the U.S. by following specific guidelines.

Degree: Academic credential given by colleges or universities to students who have completed a course of study.

Doctoral Degree: The most advanced academic degree, awarded after three to five years of additional study following completion of a master's degree (some doctoral degrees do not require a master's degree).

DREAM Act: Individuals who would have qualified under the DREAM Act are often referred to as DREAMers. The term has been used to refer to individuals in the U.S. who were brought to the country at an early age without documentation, but have assimilated to the U.S. culture and have been educated by U.S. school systems. Not all immigrant youth identify as DREAMers.

Dual Enrollment: A student in high school is also taking courses from an institution of higher learning, such as a community college or university. The college classes the student takes typically count toward their high school diploma as well as college credit.

Early Action: When a student applies for admission to a college by an early deadline (before the regular admission deadline) and receives notice of acceptance, denial, or deferment with no obligation to the university to enroll.

Early Decision: When a student applies for admission to a college by an early deadline (before the regular admission deadline), with the understanding that if accepted, the student must enroll in that school. Students should apply for early decision only to their first-choice school.

Expected Family Contribution (EFC): The portion of a family's financial resources that should be available to pay for college, based on a federal formula using the information on the FAFSA (Free Application for Federal Student Aid).

FAFSA: The Free Application for Federal Student Aid is an online form submitted annually by current and prospective college students (undergraduate and graduate) in the United States to determine eligibility for student financial aid. Students who are eligible to file the FAFSA should complete it every year.

Federal Student Aid (FSA) ID: A username and password used by current and prospective students and their parents to log in to U.S. Department of Education websites including the FAFSA website. The ID is used to sign documents electronically (it has the same legal status as a written signature).

U

Tr

Cc

Ti

M

W

Fee Waiver: Permission to not pay a fee, based on meeting some requirement or condition. In the postsecondary realm, waivers of college application fees and ACT or SAT fees are often available for students based on financial need.

Financial Aid Package: Financial Aid Packages are also referred to as Award Letter, Award Notice, or Financial Aid Offer. There are different types of aid including loans, work-study, scholarships, and grants. Loans must be repaid with interest, so it's important to consider that when you look at your total award package. Depending on the package, sometimes it can be cheaper for a student to attend an expensive school because more aid is offered to offset the cost. This is why it is important to apply to the schools you want to attend, even if you don't think you can't afford it.

Four-year University: A postsecondary institution / school that offers undergraduate (bachelor's) degrees. Many four-year universities also offer graduate (master's) degrees.

Full-time Student: A student who enrolls in at least a minimum number (determined by your college or university) of credit hours or courses.

Grade Point Average (GPA): The average of all of the course grades a student receives in high school, or in college, on a four-point scale.

Grant: A sum of money given by a government or other organization for a particular purpose. It does not have to be paid back.

Honors Course: A class that covers the same subject matter as a regular class, but enriched with greater depth and at a faster pace.

International Baccalaureate (IB): A curriculum of international education and rigorous assessment designed to help students develop the intellectual, personal, emotional, and social skills to live, learn, and work in a rapidly globalizing world.

Internship: A job in a student's field of study which may be required in some academic programs and may provide salary and / or college credit.

Ivy League: A group of long-established colleges and universities in the eastern U.S. having high academic and social prestige. It includes Harvard, Yale, Princeton, Columbia, Dartmouth, Cornell, Brown, and the University of Pennsylvania.

Letters of Recommendation: Letters of endorsement (often from high school teachers / staff) written on a student's behalf during the college and / or job application process.

Major: A concentration of study focused on a discipline, which requires completion of specific courses.

Master's Degree: An academic degree conferred by a college or university upon those who complete a prescribed study beyond the bachelor's degree.

Minor: A college or university student's declared secondary academic discipline during their undergraduate studies.

Orientation: A meeting / event many colleges offer (hours-or days-long) where incoming students and parents / guardians receive information about registering for classes, meet their advisor, and learn about school resources and policies.

Parent PLUS Loan: The Parent PLUS Loan is a federal student loan available to the parents of dependent undergraduate students. The Parent PLUS Loan offers a fixed 7.54% interest rate for the 2022-2023 school year and flexible loan limits. To be eligible, a parent can't have an adverse credit history.

Pell Grant: Money from the U.S. government to support a student's education that does not have to be paid back. Pell Grants are awarded to U.S. citizens and legal residents based on financial need and timeliness of completing the FAFSA.

Placement Test: Colleges and universities may require students to take tests to determine the appropriate level college math and / or English class.

Postsecondary Education: The broadest term to describe any education beyond high school, including, community college, university, technical school, etc.

Prerequisite: A course or courses that must be successfully completed before a student can enroll in the next level course or more advanced courses.

Residence Hall: A building primarily providing living / sleeping quarters for large numbers of students. Also known as a dorm or dormitory and often referred to as "on-campus housing."

Resident: A student who lives in and meets the residency requirements for the state where a public university is located. Tuition at public universities often is more expensive for non-residents.

Resume: A brief account of a person's education, qualifications, and previous experience, typically sent with a job application.

ROTC: Program to train college students to become officers in the U.S. Armed Forces. Stands for Reserve Officers' Training Corps.

Room & Board: The cost of a room in a dormitory and a dining hall meal plan at a college or university.

Scholarship: Money to support a student's education that does not have to be paid back. Scholarships are awarded based on academic, athletic, artistic, or other types of achievements, affiliations, or competitions.

Student Aid Report (SAR): The SAR summarizes the information included on the Free Application for Federal Student Aid (FAFSA). The SAR provides the Expected Family Contribution (EFC), which is used to determine whether a student is eligible for a federal Pell Grant and other federal aid.

Student Loan: Money a student borrows to help pay for college, which must be paid back. **Subsidized** loans are offered to students who qualify through the FAFSA. The federal government pays the interest while the student is enrolled in college at least part-time. There are also **unsubsidized** loans where interest begins accruing as soon as the loan is disbursed.

Summer Bridge Programs: Programs offered by many universities and some community colleges, which occur in the summer between high school graduation and fall transition to college, and offer students accelerated, focused learning opportunities that can help better prepare them to succeed in college.

Technical School: A general term used for a college that provides mostly employment-preparation skills for trained labor, such as welding and culinary arts. These programs generally take no more than two years to complete. Examples include the Universal Technical Institute and DeVry.

Transcript: An official academic record from a specific school. It lists when you attended, the courses you have completed, grades, and sometimes test scores. Universities, colleges, and technical schools usually require high school transcripts be submitted as part of the application process.

TRiO Programs: Federal outreach and student support service programs at the middle school, high school, and college level to assist students with understanding of basic college requirements, and to motivate students toward successful completion of postsecondary education.

Tuition: The amount of money charged for instruction / classes at postsecondary institutions (see also-- cost of attendance).

Undeclared / Undecided: Term to describe a student who is unable or not ready to select a major at a college or university. Colleges typically ask students to pick their major by the end of their sophomore year.

Work-Study: A federal program that provides the opportunity for college students to work part-time jobs (often on the campus of the school they attend) to earn money to pay educational expenses. Students receive compensation in the form of a paycheck, much like a traditional job. Students must submit the FAFSA to be considered for work-study positions.

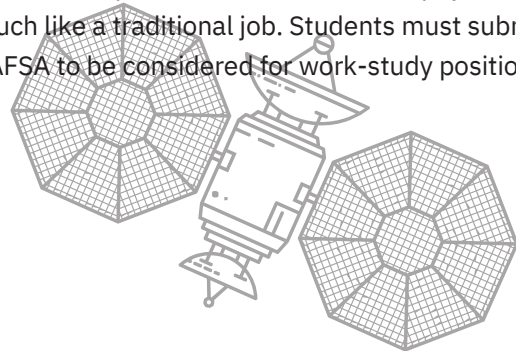



SECTION 8

Username and Passwords

WARNING: Write usernames and passwords here, with or without encryption, at your own risk. Your password is the electronic equivalent of your signature. Treat your passwords as you would treat any piece of personal and confidential information by taking measures to keep them confidential. If you choose to write your usernames and passwords here, keep tight control of this Guide at all times and if someone learns your password, or you lose this book, you should immediately change your password(s).

Name of site:		Why I use it:	
Username		Password	
Web address:			

Name of site:		Why I use it:	
Username		Password	
Web address:			

Name of site:		Why I use it:	
Username		Password	
Web address:			

Name of site:		Why I use it:	
Username		Password	
Web address:			

Name of site:		Why I use it:	
Username		Password	
Web address:			

More Usernames and Passwords



Name of site:		Why I use it:	
Username		Password	
Web address:			

Name of site:		Why I use it:	
Username		Password	
Web address:			

Name of site:		Why I use it:	
Username		Password	
Web address:			

Name of site:		Why I use it:	
Username		Password	
Web address:			

Name of site:		Why I use it:	
Username		Password	
Web address:			



WE HAVE LIFT-OFF!

Nebraska GEAR UP (Gaining Early Awareness and Readiness for Undergraduate Programs) is made possible by a grant from the U.S. Department of Education. Through partnerships with universities and others, GI GEAR UP is significantly increasing the number of students from low-income communities who stay in school and are prepared to enter and succeed in postsecondary education. Learn more at gips.org/Page/1700

The federal government does not endorse this Guide, nor do its contents necessarily represent the policy of the Department of Education.

Grand Island GEAR UP | Grand Island Senior High | 2124 N Lafayette Ave | Grand Island, NE 68801 | gips.org/Page/1700